

Are We Falling Off the «Net Energy Cliff» ...

+Johann W. Kolar* et al.

+Swiss Federal Institute of Technology (ETH) Zurich / TU Wien*

+Advanced Mechatronic Systems Group / Power Electronics Research Group*
www.pes.ee.ethz.ch

Dec. 5, 2024



... and Running Out of Critical Raw Materials ?

+Johann W. Kolar* | +Jonas Huber | +Luc Imperiali | Uwe Drogenik*

+Swiss Federal Institute of Technology (ETH) Zurich / TU Wien*

+Advanced Mechatronic Systems Group / Power Electronics Research Group*

www.pes.ee.ethz.ch

Dec. 5, 2024



Are We Falling Off the «Net Energy Cliff» and Running Out of Critical Raw Materials?

Abstract — Since the Industrial Revolution, economic growth has been enabled by fossil fuels, which remain indispensable in applications like long-haul transport or the production of chemicals, steel, and cement. Any energy supply system must provide sufficient surplus energy after accounting for the energy required to build and maintain that system, i.e., the Energy Return on Energy Invested (EROEI) must be higher than about 5...10 for supporting complex industrial societies. This is easily achieved by burning fossil fuels, which, however, causes global warming. Therefore, a clean energy transition towards renewable energy is mandatory and underway. This transition comes with challenges such as the need for energy storage and new long-distance power transmission lines; if accounted for these, a 100% renewable energy system might show EROEI values of less than 5. Further, the transition requires substantial amounts of critical minerals, which exceed known reserves in some cases and/or whose sourcing and processing is geopolitically constrained. These aspects motivate, first, a “do-more-with-less” approach in power electronics, i.e., highly compact and highly efficient power converters, and second, the need to follow a zero-waste paradigm towards fully circular economy compatible power electronics.

Outline



- ▶ *Introduction*
- ▶ *Net-Zero CO₂ by 2XXX*
- ▶ *The «Net Energy Cliff»*
- ▶ *Raw Material Constraints*
- ▶ *Zero End-of-Life Waste*
- ▶ *Conclusions*

Industrial/Energy Revolutions 1- 4

- **Technological / Economic Advances and Massive Increase of Fossil Fuel Consumption**
- **Transition from Lower to Higher Energy Density Fuel — Wood → Coal → Oil & Gas**

Energy consumption in the United States (1776–2021)
quadrillion British thermal units

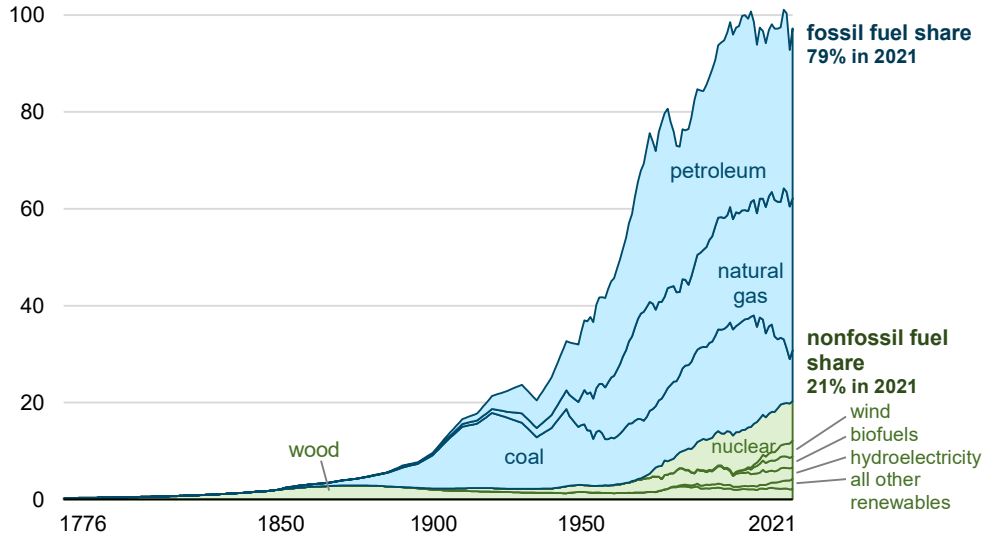

Energy use per person vs. GDP per capita, 2022

Energy refers to primary energy¹, measured in kilowatt-hours² per person, using the substitution method³. Gross domestic product (GDP) is adjusted for inflation and differences in the cost of living between countries.

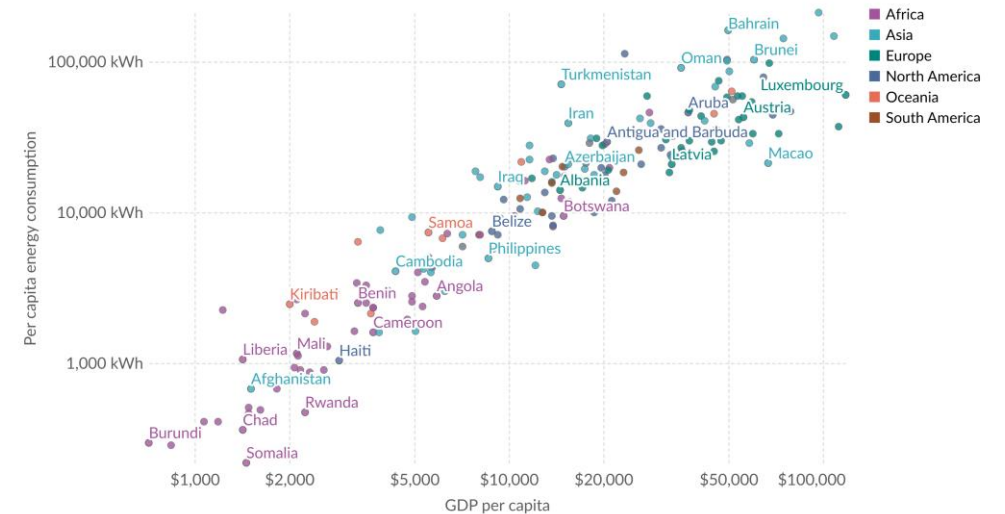

- **Relation of Energy Use & GDP/Capita — There are No Low-Energy Rich Countries (!)**
- **Gains in Energy Intensity of GDP Potentially Resulting from Offshoring of Energy-Intense Manufacturing**

Energy for Transportation

- *Kitty Hawk – 1st Sustained Flight of Manned Heavier-than-Air Powered Controlled Aircraft (1903)*
- *9 kW / 80 kg Engine / Lightweight Alumina Cast Motor Block / High Energy Density Gasoline*

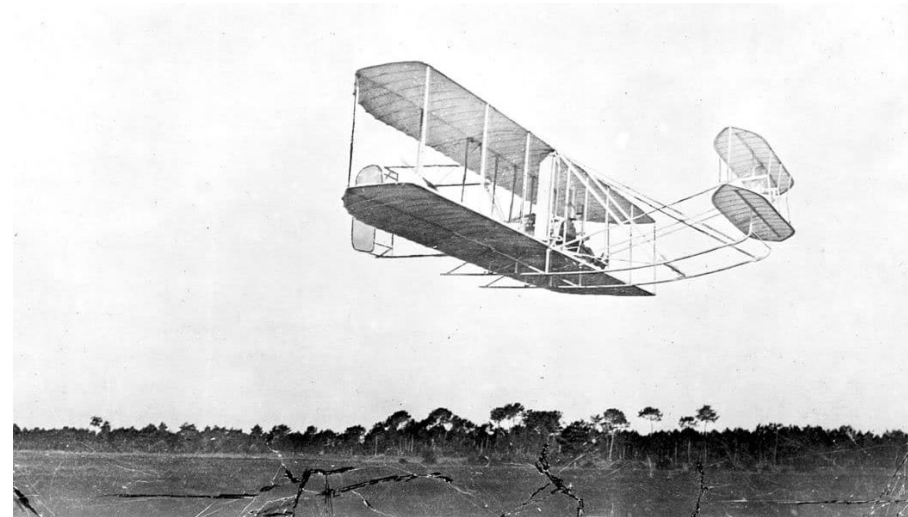
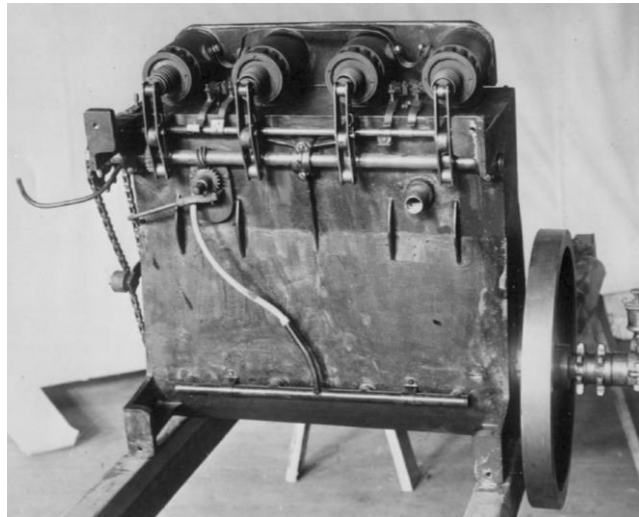

- *Air/Sea/Land Transportation Remains Dependent on Inefficient ICes / Gas Turbines / Liquid Fossil Fuels*
- *Accounts for $\approx 2/3$ of Global Oil Use & 15% of Global Greenhouse Gas Emissions*

Energy for Chemicals

- **11% / 8% Global Oil / Gas Used for Production of Chemicals — Fertilizers, Pharmaceuticals, Plastics etc.**
- **50+% of Energy Input as “Feedstock” Finally Embedded in Products (Globally ≈1 Mio PET Bottles/min)**

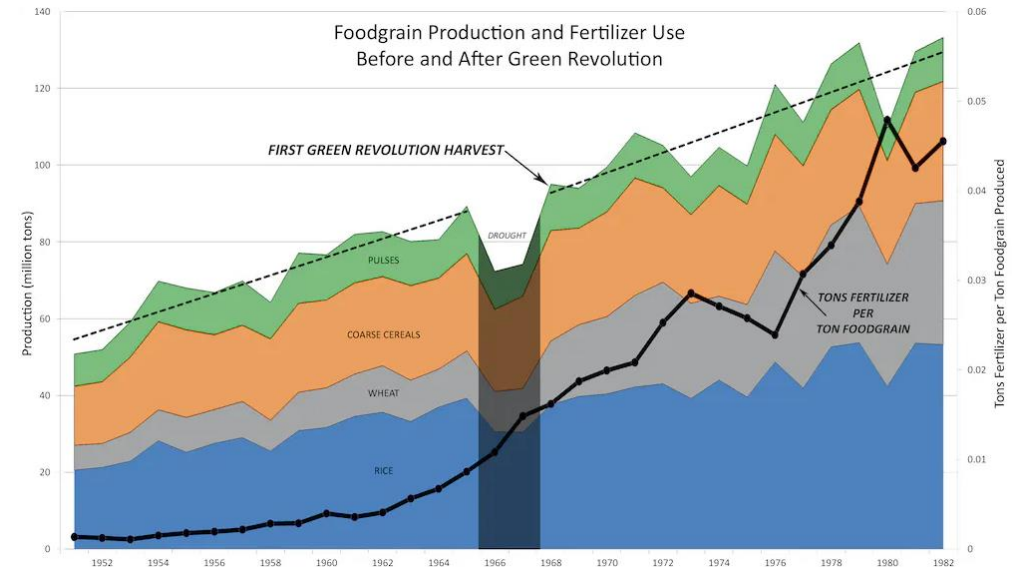
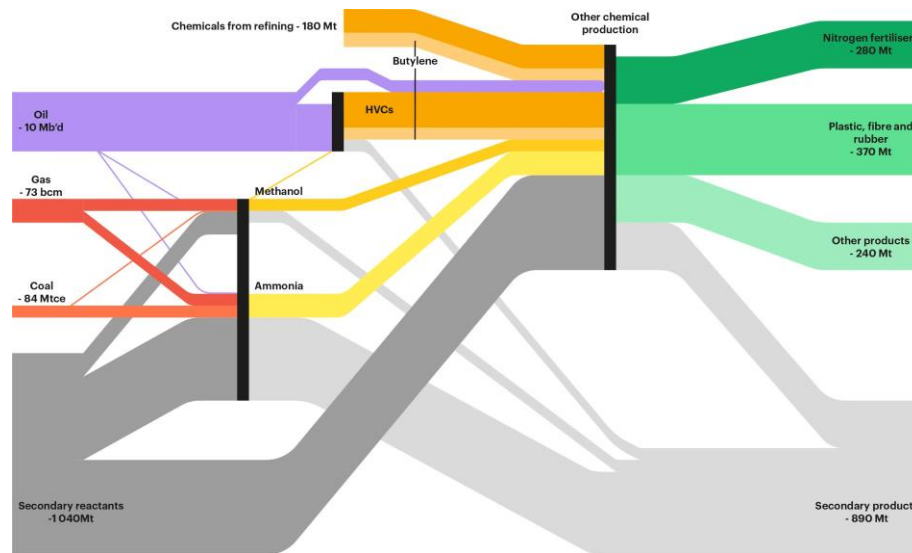

- **“Green Revolution” in Mid-20th Century — Higher Yield Due to Use of Fertilizers & Pesticides & Mechanization**
- **Chemical Sector — Largest Industrial Energy Consumer / 3rd Largest CO₂ Emissions after Steels & Cement**

Energy for Cement Production

- **Cement — Key Ingredient in Concrete / Chemical Process & High Heat / 8% of Global CO₂ Emissions**
- **Concrete is the Most Consumed Human-Made Material on Earth / Buildings & Infrastructure etc.**

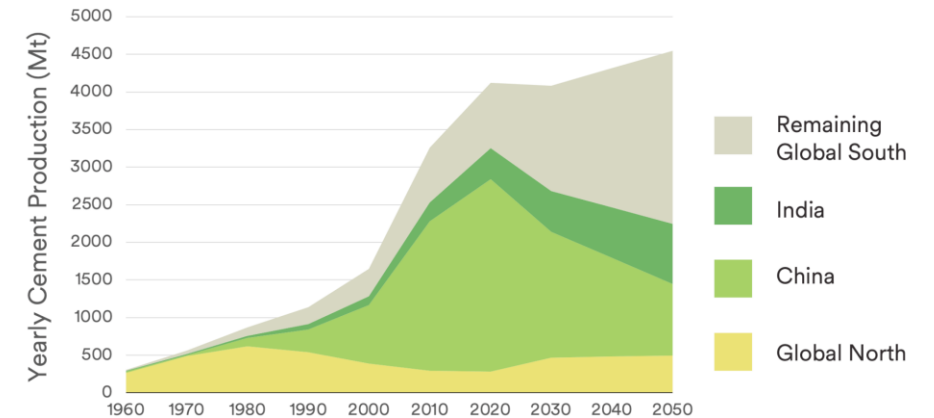
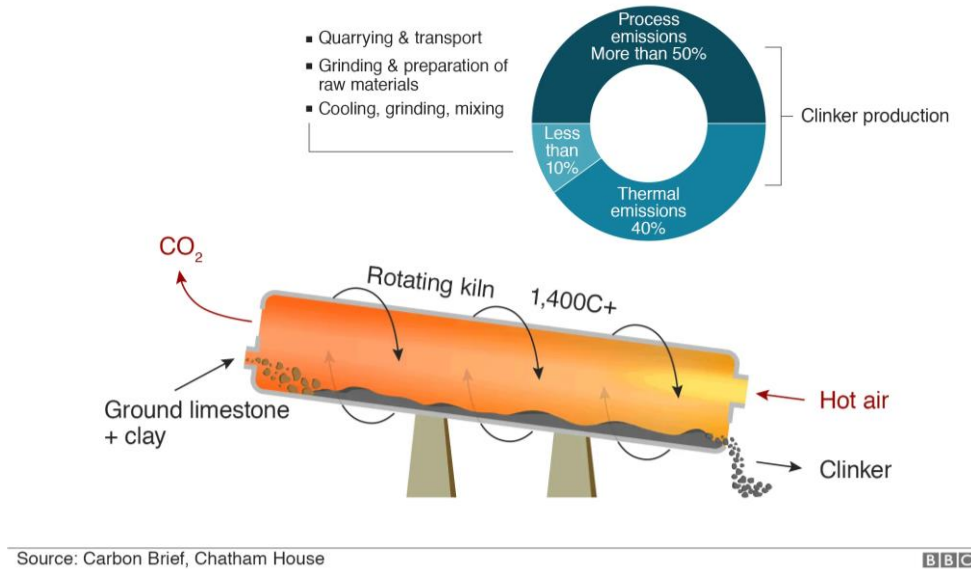

- **China and India Account for Around Half of Global Cement Production**
- **Intensity of Cement Use Declines After Initially Rising w/ Increasing GDP/ Capita**

Energy for Steel Production

- **Crude Iron Production in Blast Furnaces Highly Reliant on Coal/Coke as Reducing Agent to Extract Iron from Ore**
- **Basic Oxygen Converter Turns Crude Iron into Easily Formable Steel / Electric Arc Furnaces Recycle Steel Scrap**

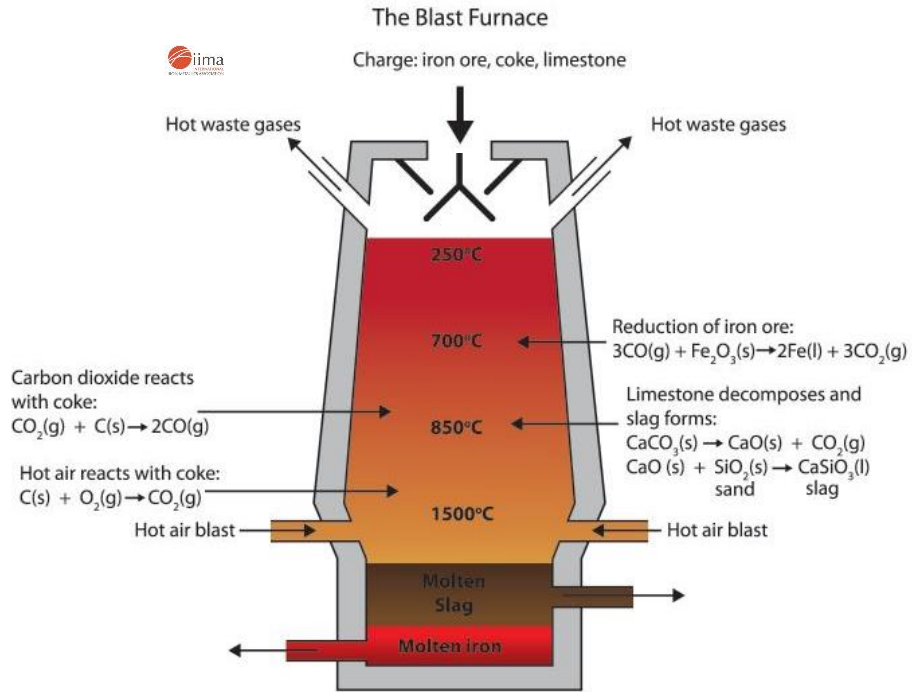

K. Hea / Li Wang (2016) <http://dx.doi.org/10.1016/j.rser.2016.12.007>

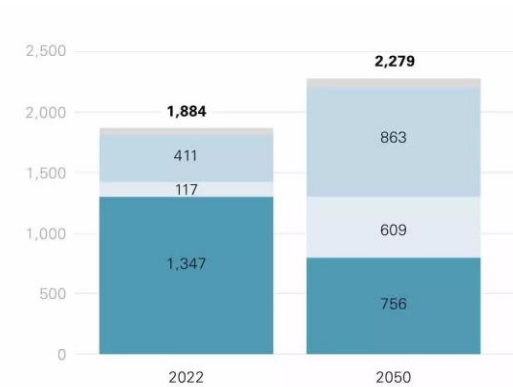
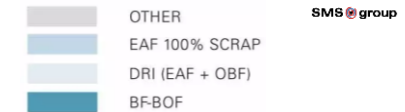
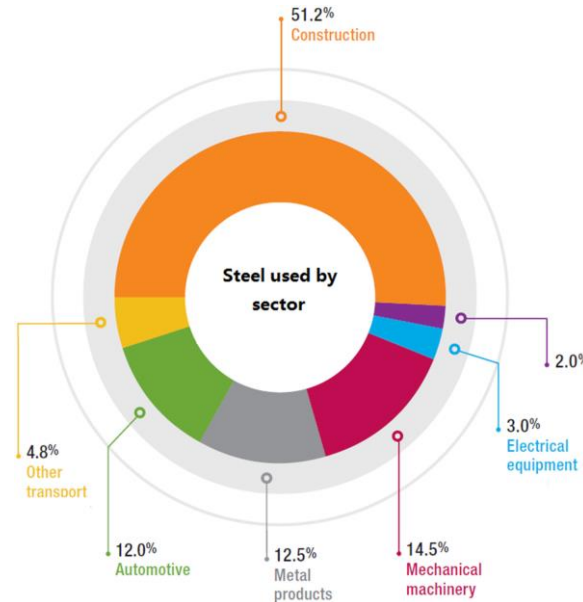

- **Steel Production Responsible for ≈8% of All Global Direct Emissions From Fossil Fuels**
- **Global Steel Demand Expected to Increase from ≈1.9 Billion Tons/a in 2021 to Over ≈2.3 Billion Tons/a by 2050**

Global Energy Use Today

■ *Global Energy Flows — 2021*

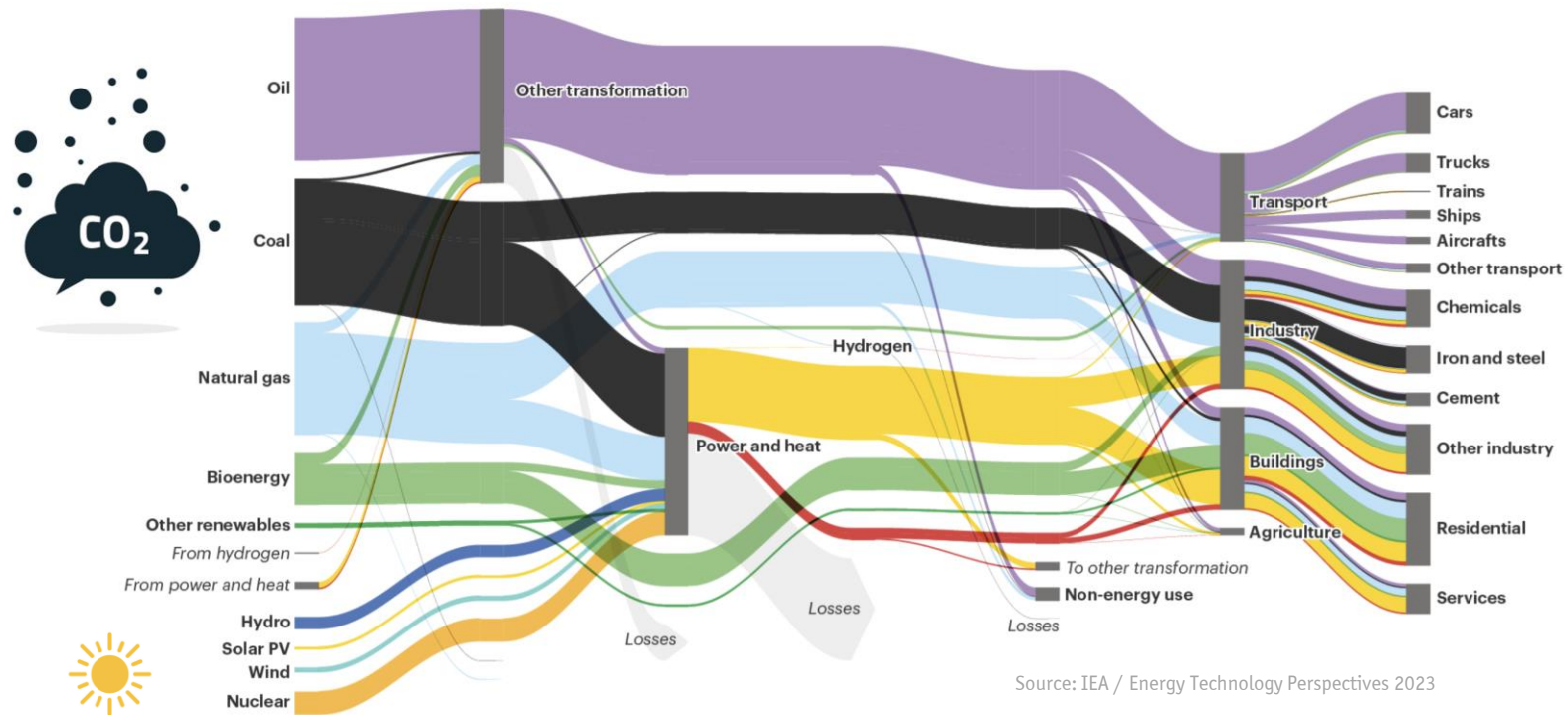

- *Fossil Fuels Account for ≈ 80% of World's Primary Energy Consumption*
- *Low Average Efficiency of Energy Use*

Energy Return on Energy Invested (EROEI)

- Energy Supply Must Provide Sufficient Energy Surplus after Accounting for Own Energy Requirements
- Energy Invested for Production / Transformation / Transportation

$$\text{EROEI} = \frac{\text{Energy Obtained}}{\text{Energy required to obtain that energy}} \rightarrow \text{Net Energy} = \text{Energy Obtained} \cdot \left(1 - \frac{1}{\text{EROEI}}\right)$$

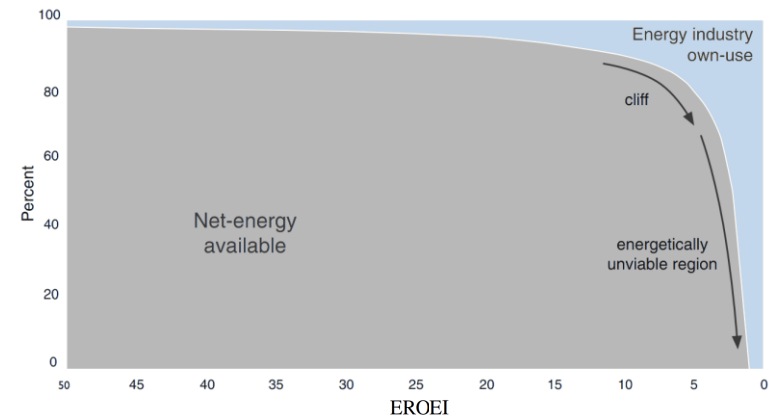
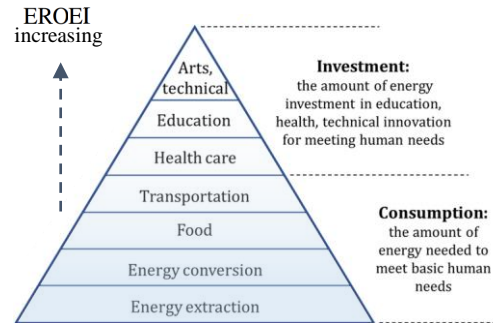
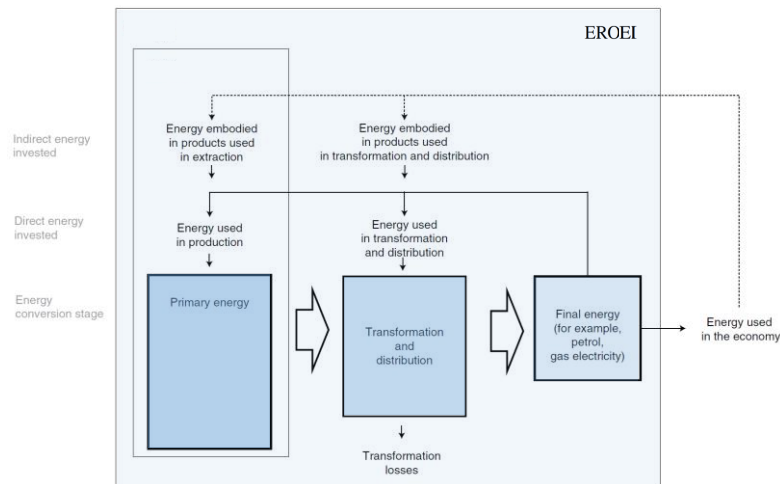

- "Pyramids of Energy Needs" — Higher EROEI Values Enable Medical Care/Education/Technology Innovation/Art etc.
- The "Net Energy Cliff" Indicates the Minimum EROEI = 5...10 Required to Maintain a Complex Industrial Society

Energy Return on Energy Invested (EROEI)

- Energy Supply Must Provide Sufficient Energy Surplus after Accounting for Own Energy Requirements
- Energy Invested for Production / Transformation / Transportation

$$\text{EROEI} = \frac{\text{Energy Obtained}}{\text{Energy required to obtain that energy}} \rightarrow \text{Net Energy} = \text{Energy Obtained} \cdot \left(1 - \frac{1}{\text{EROEI}}\right)$$

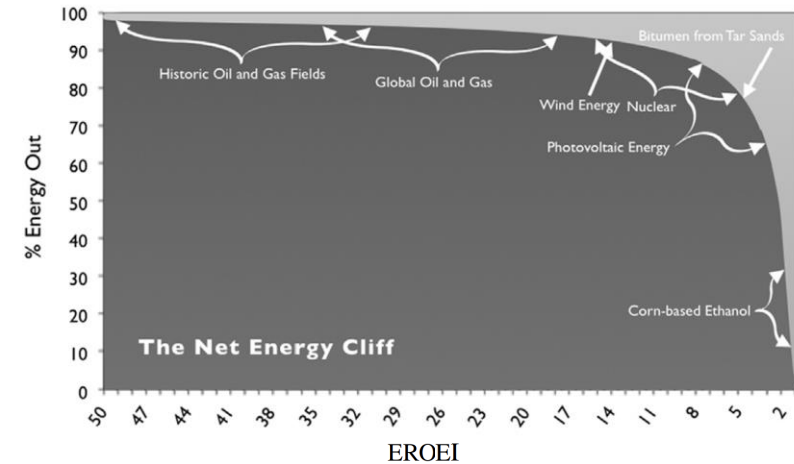
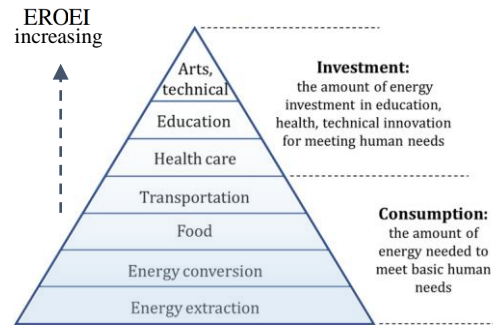
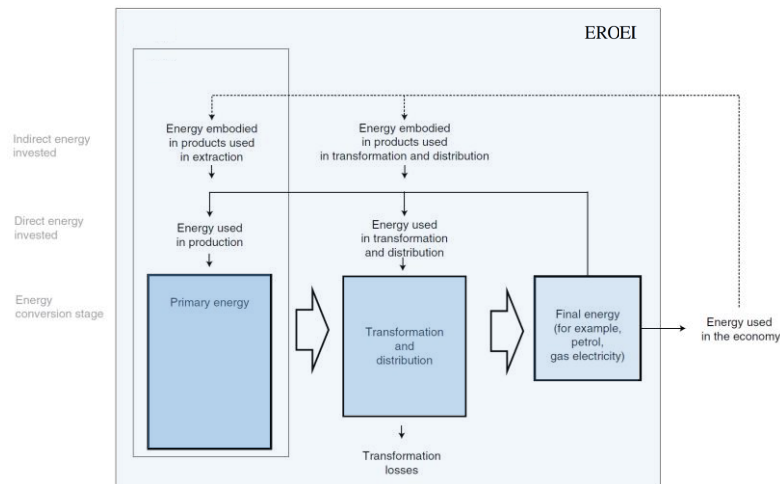

- "Pyramids of Energy Needs" — Higher EROEI Values Enable Medical Care/Education/Technology Innovation/Art etc.
- The "Net Energy Cliff" Indicates the Minimum EROEI = 5...10 Required to Maintain a Complex Industrial Society

Future Population Growth

- **Growth of World Population & Growth of Energy Use per Capita**
- **1980 — 4.4 Billion | ≈ 10 TW.yr → 2022 — ≈ 8 Billion | 20.4 TW.yr**

Global population size: estimates for 1700-2022 and projections for 2022-2100

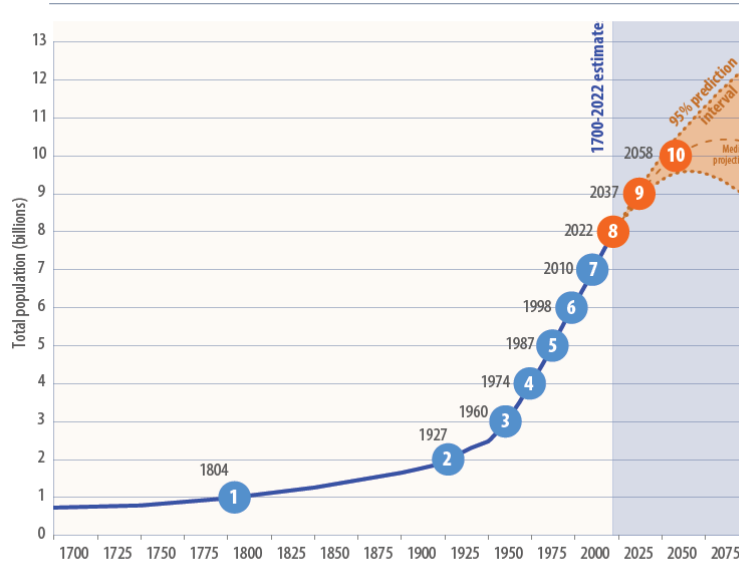

Source: United Nations, DESA, Population Division (2022). World Population Prospects 2022.

Energy use per person, 2021

Energy use not only includes electricity, but also other areas of consumption including transport, heating and cooking.

Our World in Data

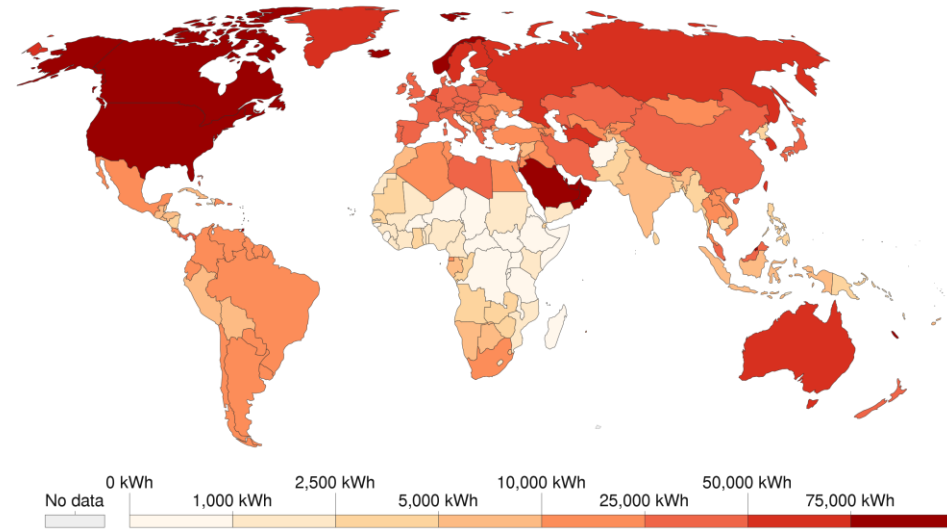

Source: Our World in Data based on BP & Shift Data Portal
 Note: Energy refers to primary energy – the energy input before the transformation to forms of energy for end-use (such as electricity or petrol for transport).

- **2022 Global Energy Consumption per Capita — 22'400 kWh avg. | 2.6 kW avg. (2.3 kW avg. in 1980)**

Future Growth of Energy Demand



- **Growing Population & GDP — Increasing Demand for Energy Services in Developing Countries**
- **+22% Population | +92% GDP/Cap | -37% Energy Intensity → +50% Energy Demand by 2040 Globally**

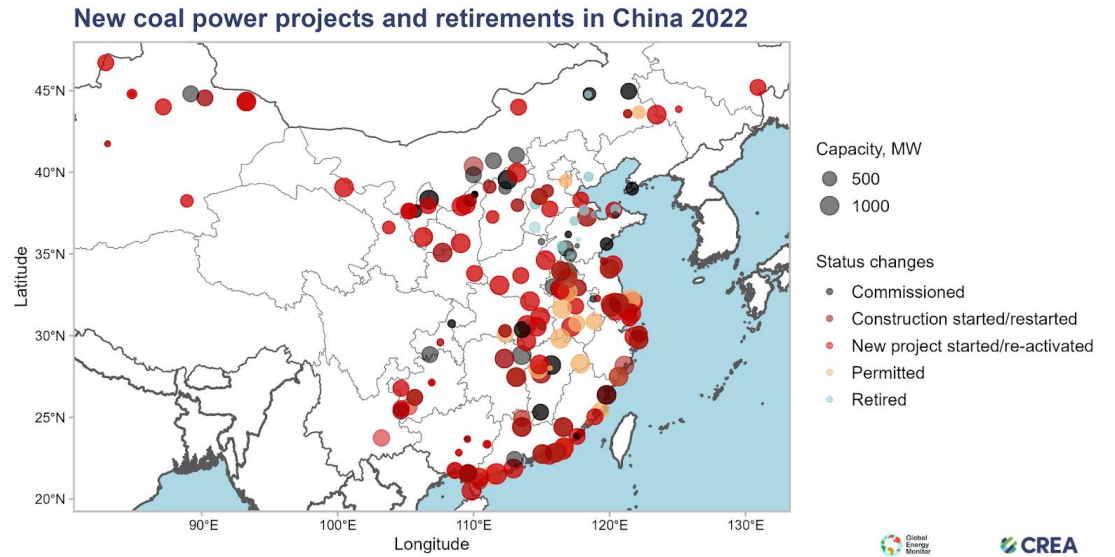

- **106 GW of New Coal Power Projects Permitted in China in 2022 — 2 Large Coal Power Plants / Week**
- **50 GW Coal Power Capacity Construction Started / 50% Increase from 2021 | 26 GW Added | 4.1 GW Closed Down**

Energy Dependence / Limited Security of Supply

- **Global Oil Trade (2016) — High Import Dependency of Leading Economies**

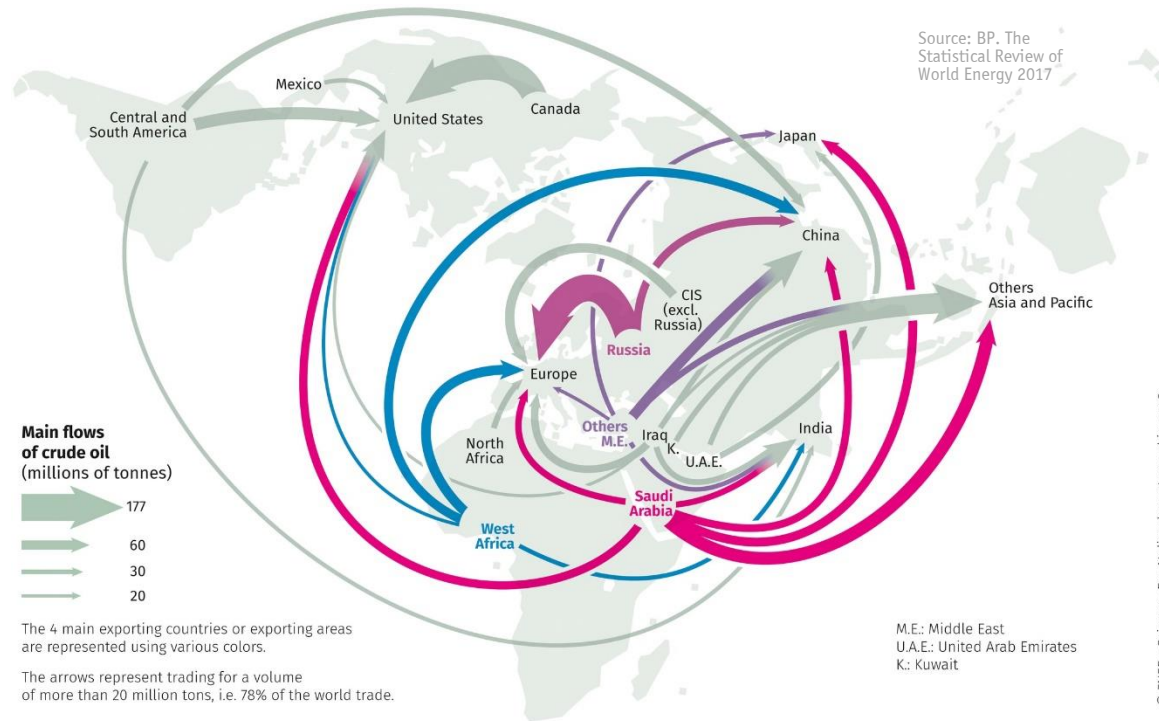

- **Finite Resources Fossil Fuels are Unable to Sustain Economic Development in the Long Term (!)**
- **“The Stone Age Didn't End for Lack of Stone — The Oil Age will End Long Before the World Runs Out of Oil”**

Global Warming

- **Cumulative CO₂ Emissions & Global Surf. Temp. — Every Ton of CO₂ Adds to Global Warming (!)**

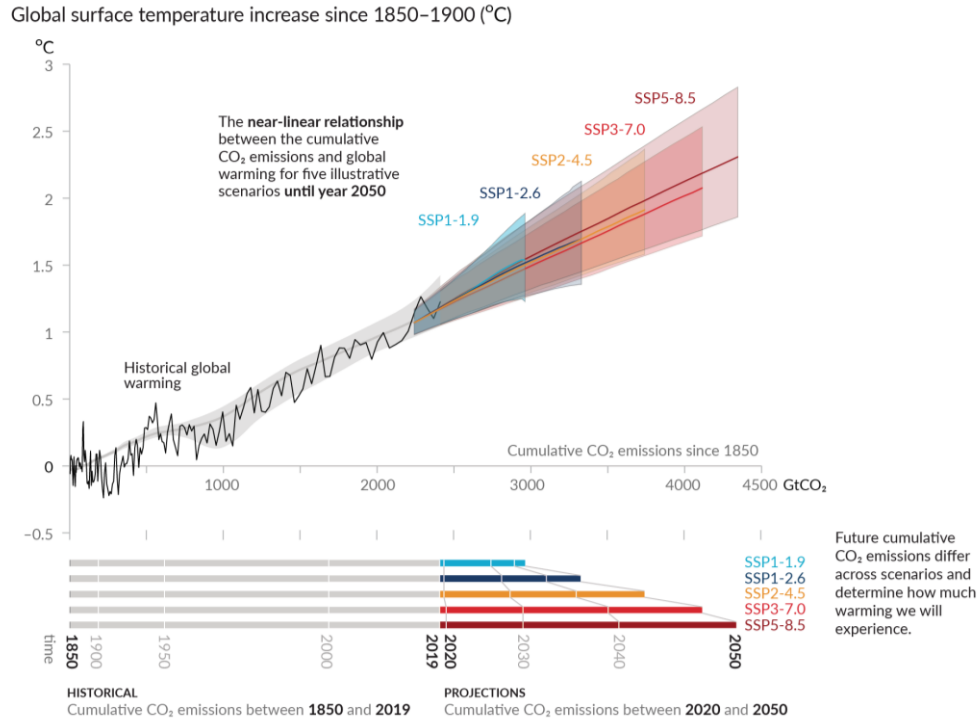

Source: Ch. McGlade et al. doi:10.1038/nature14016

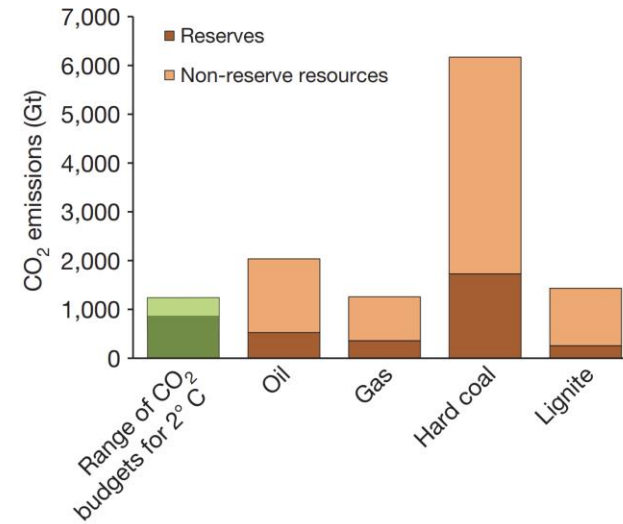

- **2° C Target → 30% of Oil Reserves | 50% Gas Reserves | > 80% Coal Reserves Should Remain Unused (!)**

Global Sea Levels by 2100

- **Rising Sea Levels Due to Global Warming**
- **IPCC Predictions for Low/High Emissions Scenario**

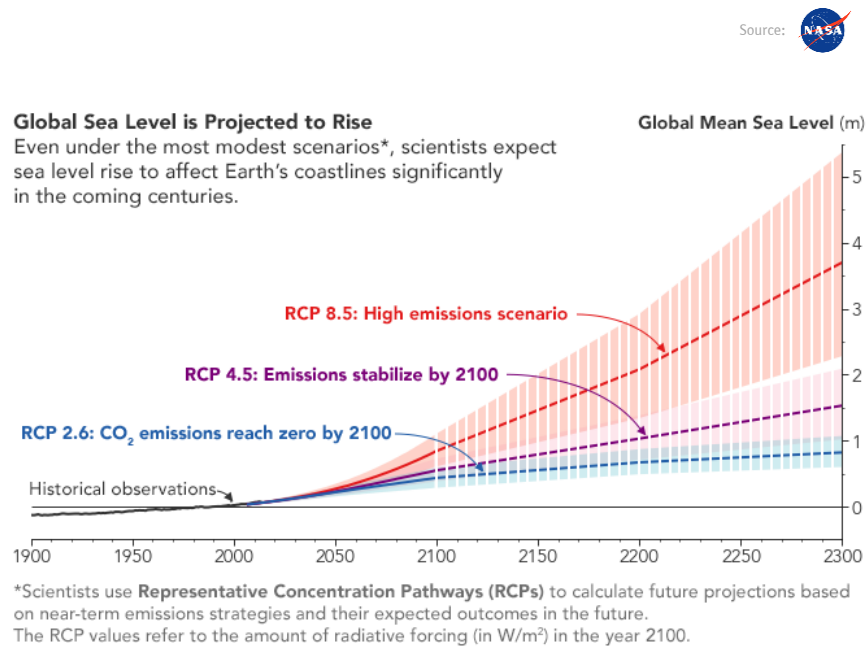

@ 2°C Temp. Increase

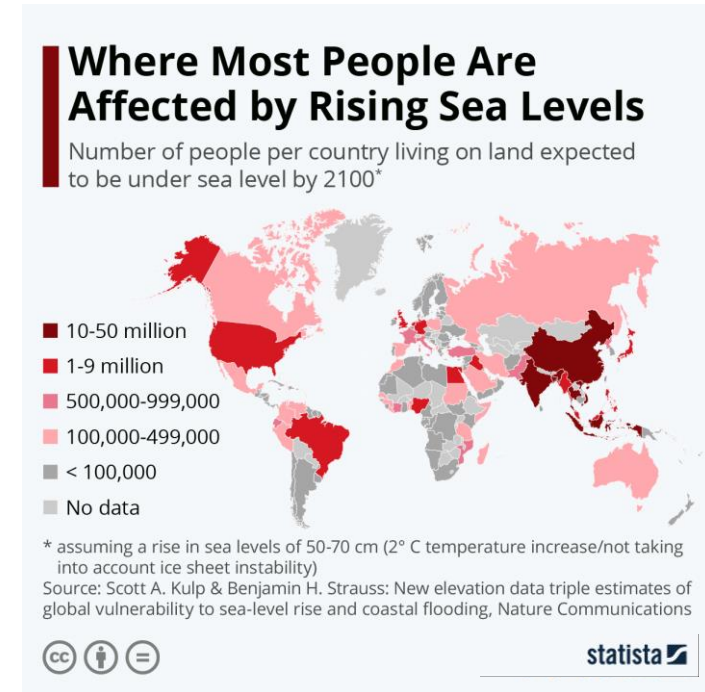

- **200 Million People will Globally Live Below the Sea Level Line by 2100**
- **Add. 160 Million Affected by Higher Annual Flooding Due to Rising Ocean Levels**

Air & Environmental Pollution

- **2018 — Burning Fossil Fuels / Exposure to Fine Particle Matter PM 2.5 Responsible for 8.7 Million Deaths**
- **Airborne Particles up to 2.5um Diameter Penetrate Deep into Lungs - Enter Bloodstream – Damage Organs**

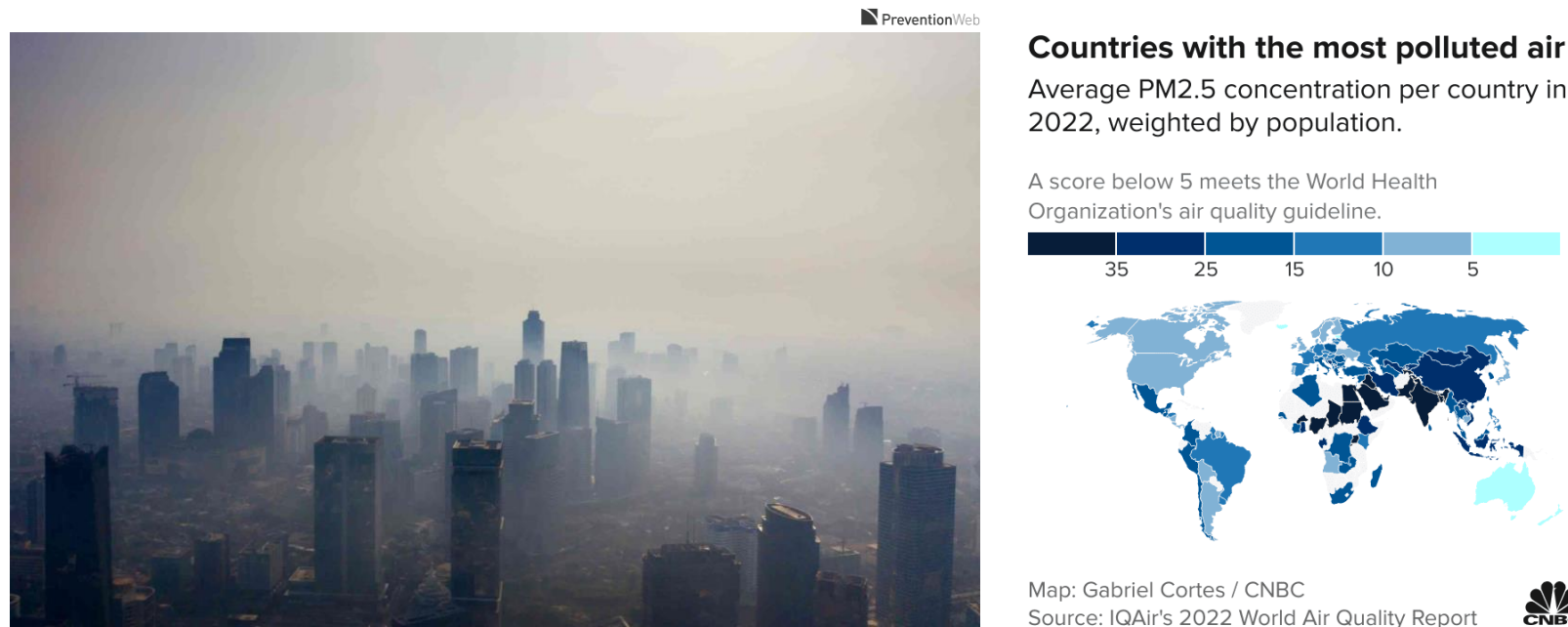

- **Links between PM 2.5 Pollution & Cardiovascular Disease / Lung Cancer / Asthma etc. Well Documented**
- **Further Health Consequences by Ozone Air Pollution or Smog also Driven by Combustion of Fossil Fuel**

Clean Energy Transition

Renewable Energy Utilization

Transmission / Storage / Power-to-X Challenges

The Net Energy Cliff

Decarbonization / Defossilization

- "Net-Zero" Emissions by 2050 & Gap to be Closed
- 50 GtCO_{2eq} Global Greenhouse Gas Emissions / Year → 280 GtCO₂ Budget Left for 1.5°C Limit

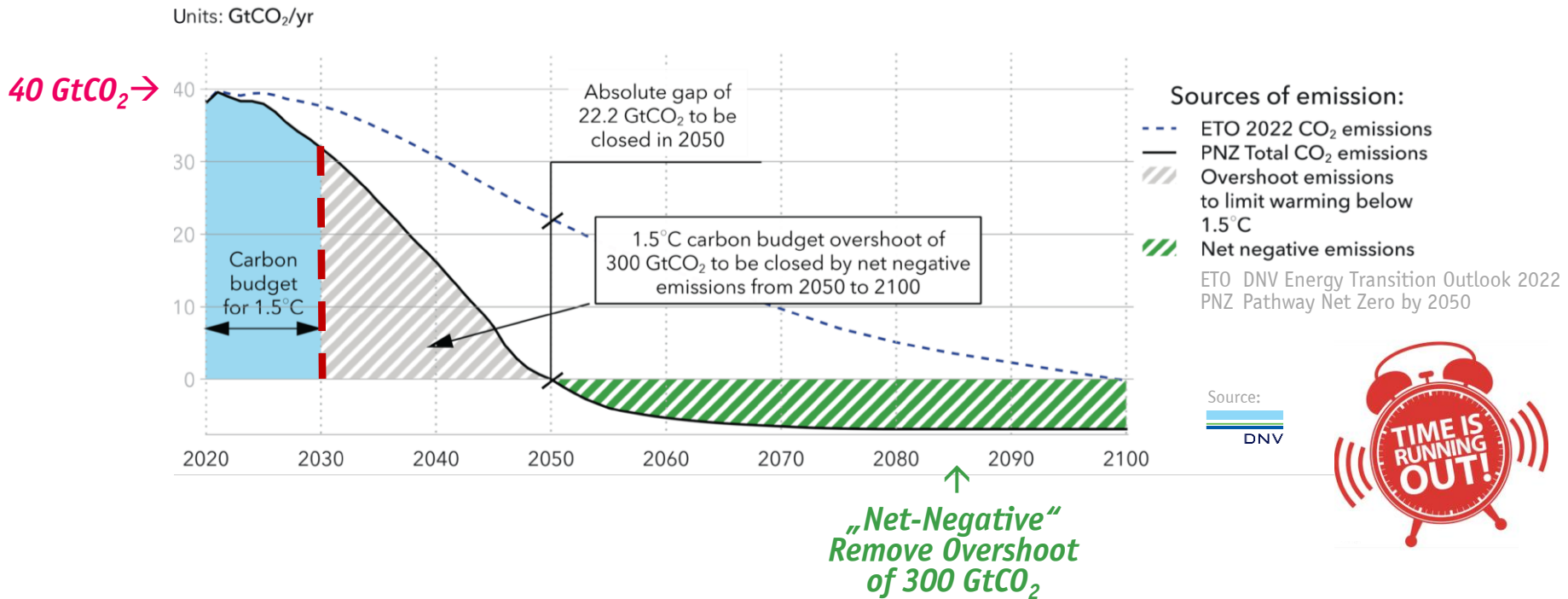

- Challenge of Stepping Back from Oil & Gas

Renewable Energy Utilization

- Outlook of Global Cumulative Installations Until 2050 / Add. 1000 GW Off-Shore Wind Power
- In 2050 Deployment of 370 GW/Year (PV) & 200 GW/Year (On-Shore Wind) incl. Replacements

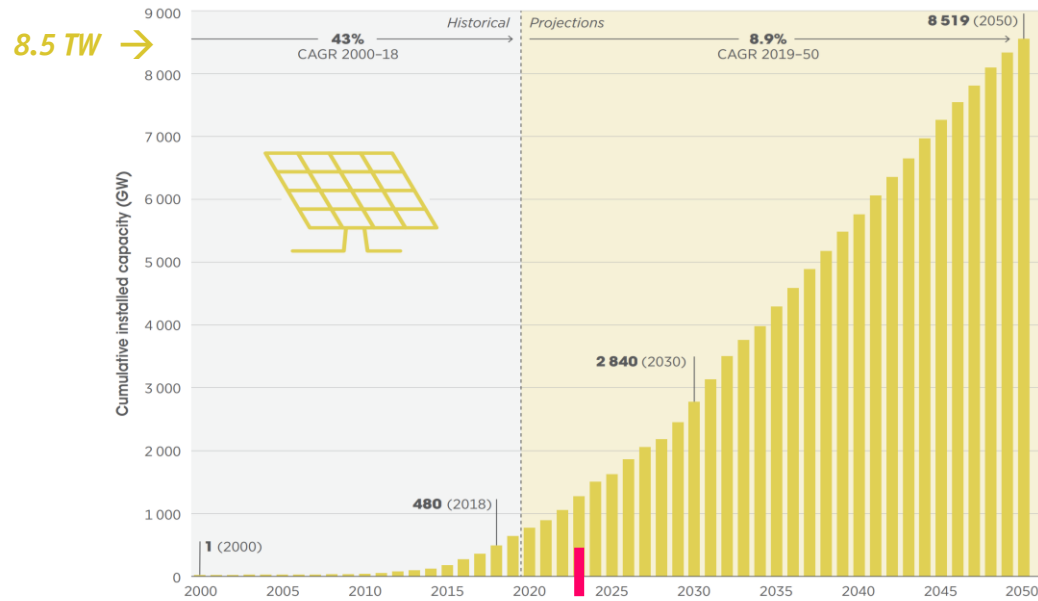

Sources: Historical values based on IRENA's renewable energy statistics (IRENA, 2019c) and future projections based on IRENA's analysis (2019a).

■ CAGR of $\approx 9\%$ up to 2050 \rightarrow 8500 GW

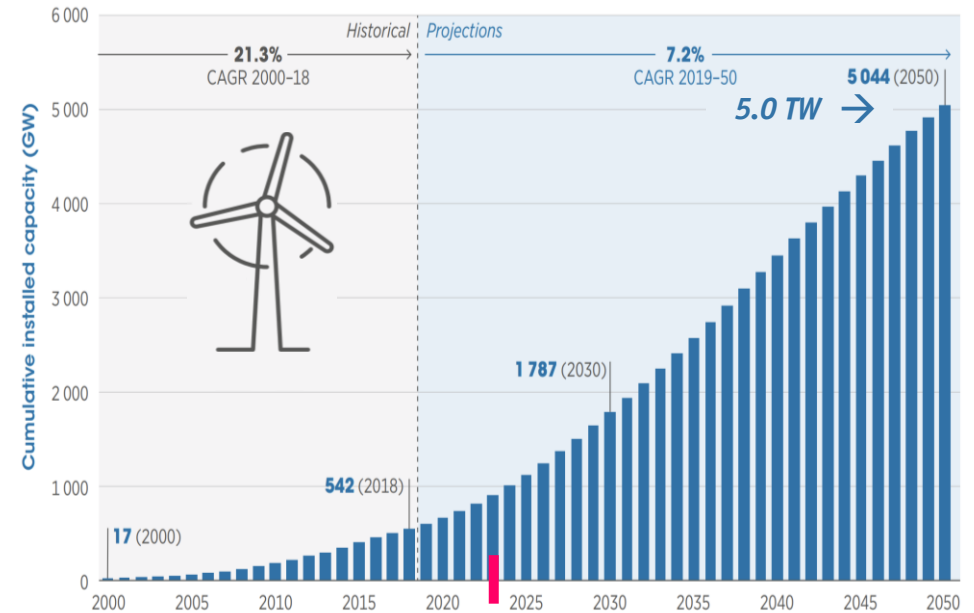

Source: Historical values based on IRENA's renewable capacity statistics (IRENA, 2019d) and future projections based on IRENA analysis (IRENA, 2019a).

■ CAGR of $\approx 7\%$ up to 2050 \rightarrow 5000 GW

Global Energy Use by 2050

■ Global Energy Flows — 2050 / Net-Zero Scenario

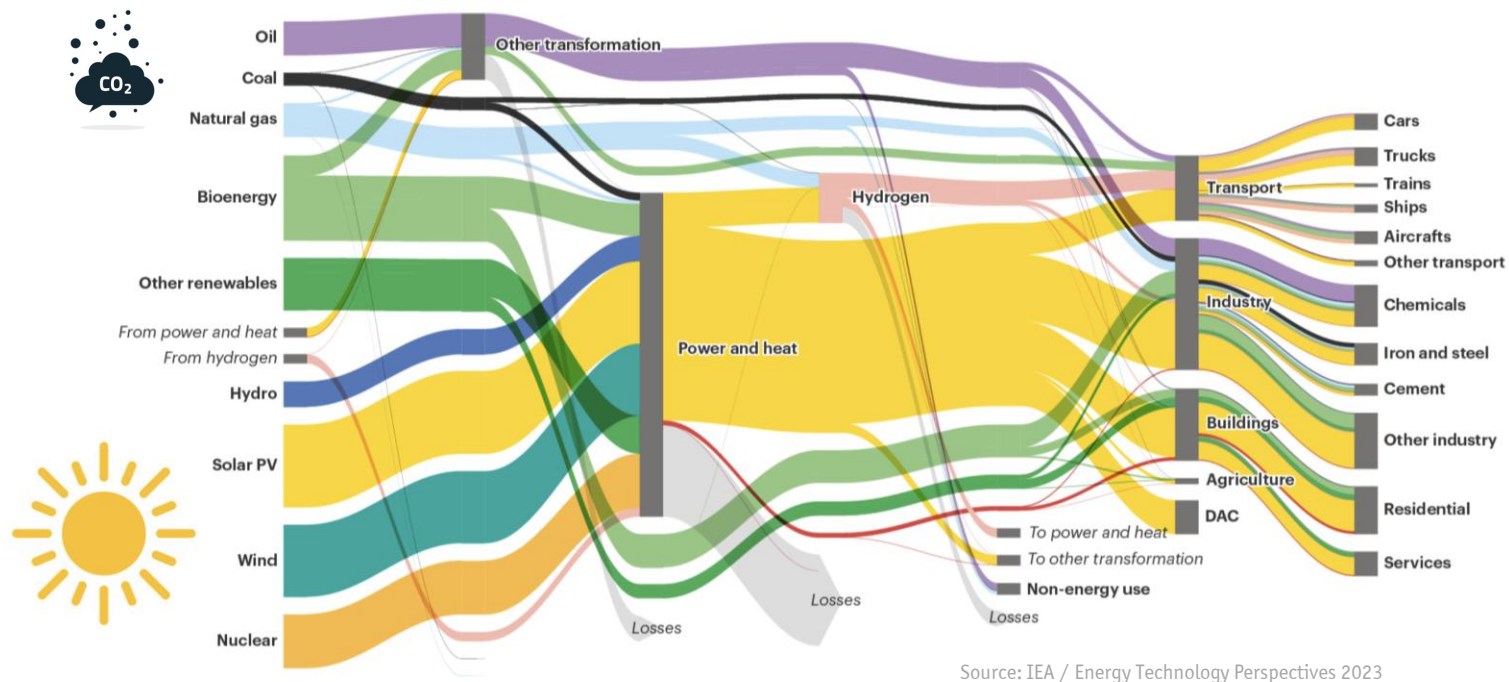

■ Dominant Share of Electric Energy — Power Electronics as Key Technology (!)

Remark Efficiency – The 5th Fuel

- Significant Reduction of Energy Demand Through Application of Existing Technology
- Electrification & Electronic Control / Sector Coupling etc.

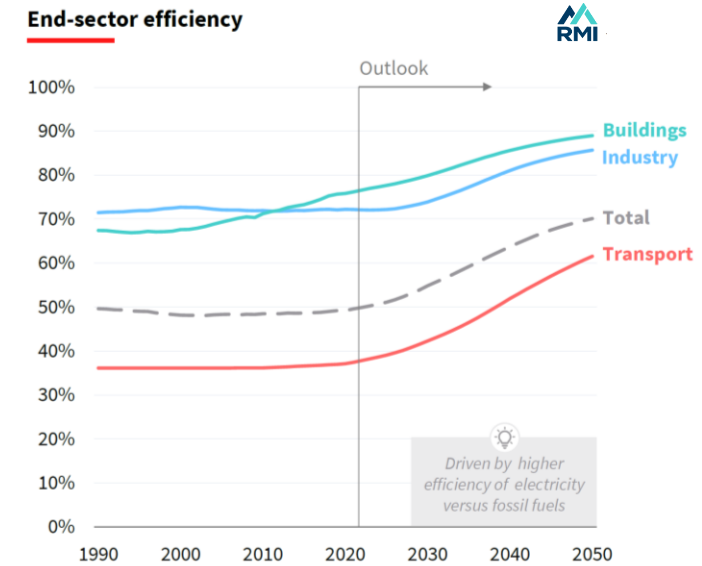
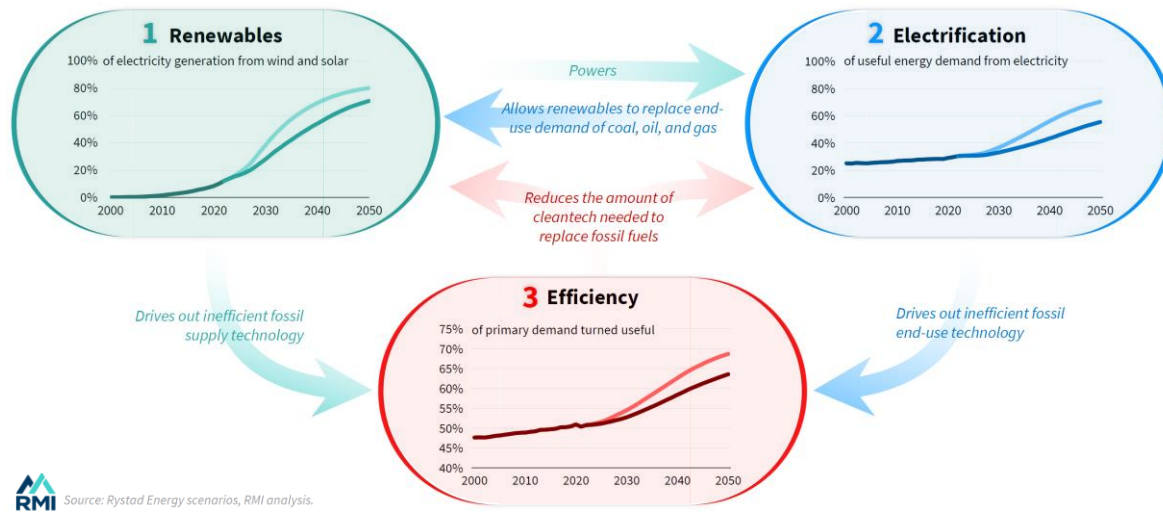

- Utilizing the "5th Fuel" Can Enable a Carbon-Free Energy System a Decade or More Earlier
- Positive Feedback Loops Between Renewables / Electrification / Efficiency

Challenge #1 — Energy Storage

- *Solar & Wind Critically Affected by Intermittence & Variability / Day-Night / „Dunkelflaute“ / Summer-Winter*
- *Energy Storage Mandatory for Ensuring Continuous Availability Comparable to Fossil Fuels*

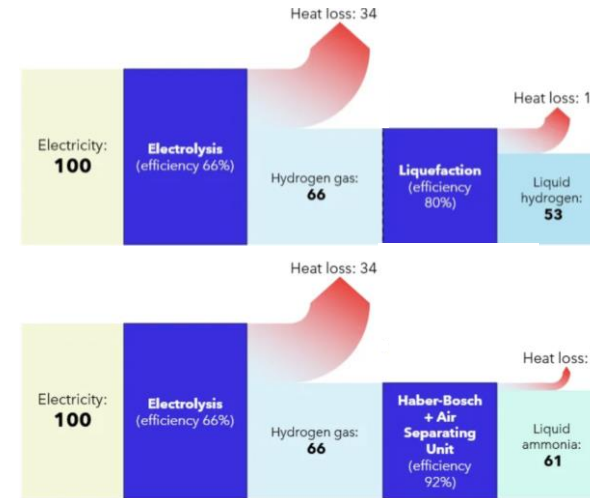
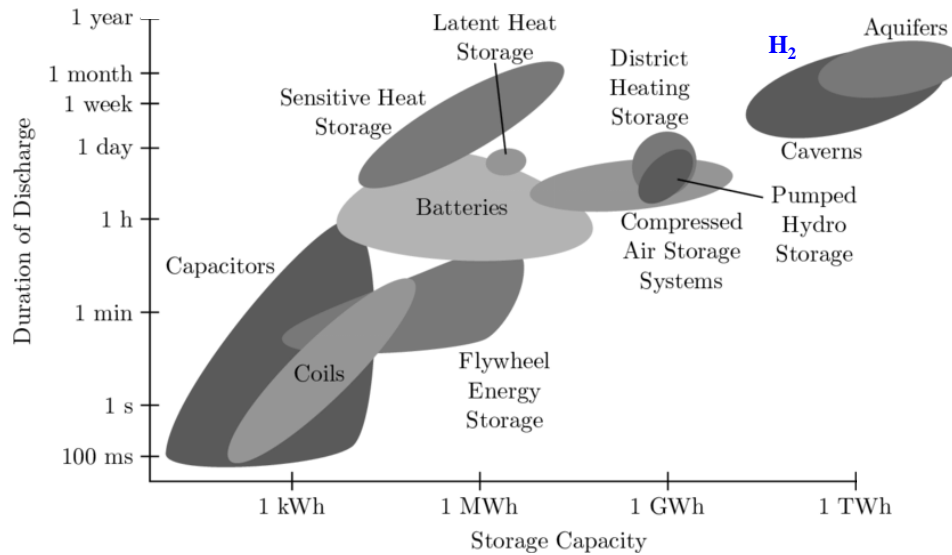

- *Conversion Losses & Storage Material Effort Result in Lower Energy System EROEI (!)*
- *Adv. Scaling of Heat Storage / Sector Coupling & Novel Storage Technologies (Iron Ore/“Rust” as H₂ Storage)*

Challenge #2 — Power-to-X-to-Power 1/2

- *GWs of Green Power Converted into X = Carbon-Neutral E-Fuels Used & long-Term Stored as Fossil Fuels OR Chemicals*
- *Hydrogen Economy — H₂ Produced & Used Directly or in Synthesis w/ Nitrogen or Carbon (Ammonia, Methanol, etc.)*

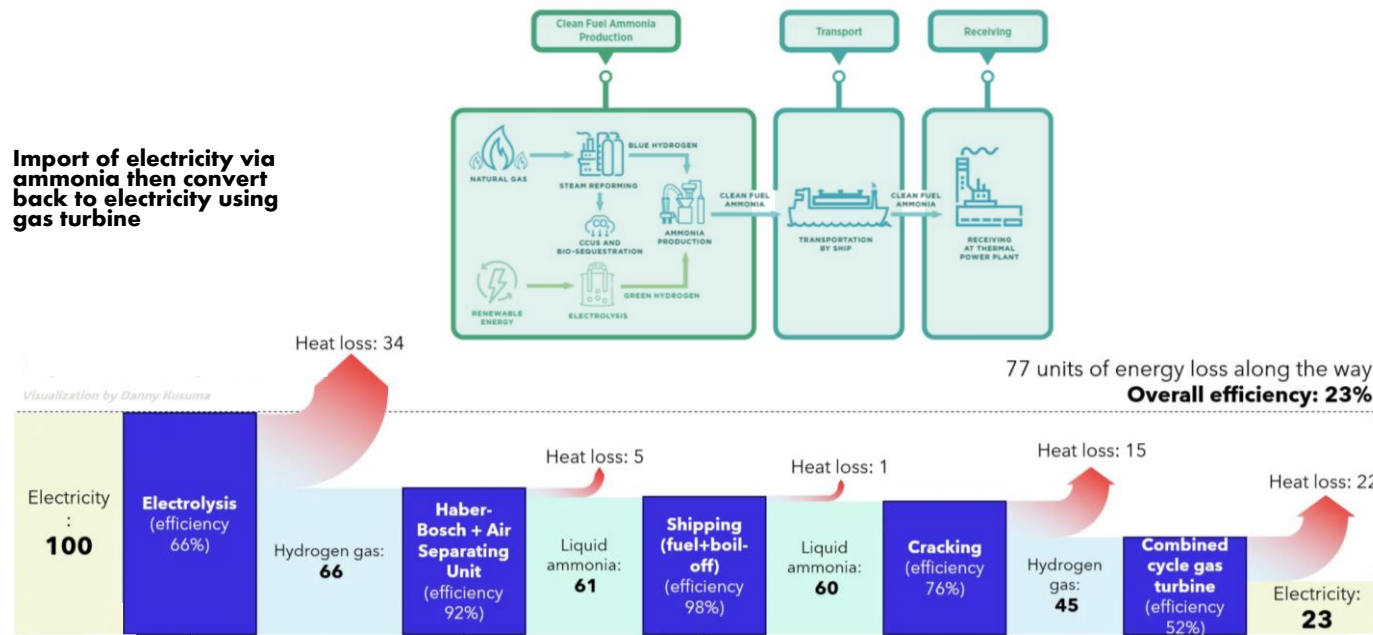

Source: Medium / Danny Kusuma

- *Hydrogen Hype — A Story of Energy Loss (?) / Direct Electrification Superior if Possible*
- *60% Efficiency of Electrolysis / 50% Efficiency of Fuel Cells / 42% Efficiency for Liquid Hydrogen Production*

Challenge #2 — Power-to-X-to-Power 2/2

- *GWs of Green Power Converted into X = Carbon-Neutral E-Fuels Used & long-Term Stored as Fossil Fuels OR Chemicals*
- *Hydrogen Economy — H₂ Produced & Used Directly or in Synthesis w/ Nitrogen or Carbon (Ammonia, Methanol, etc.)*

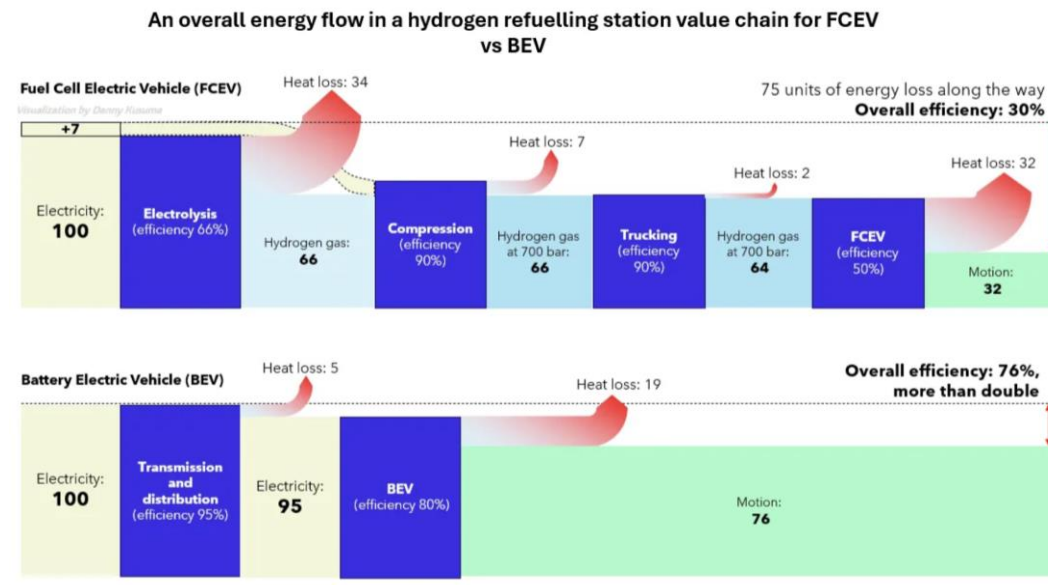

An energy-wasting proposal: Use hydrogen to replace gas for residential heating. This idea will never be realized as heat pumps have a “magic efficiency” of 300%.



Source: Medium / Danny Kusuma

- *Hydrogen Hype — A Story of Energy Loss (?) / Direct Electrification Superior if Possible*
- *60% Efficiency of Electrolysis / 50% Efficiency of Fuel Cells / 42% Efficiency for Liquid Hydrogen Production*

Challenge #3 — Long Distance Transmission

- Growth of Transmission in Line w/ Growth of Electricity Generation Capacity | 10 TW → ≈10 Million km HV Lines
- UHVDC Transmission Lines Connecting Megacities to Remote Wind & Coal-Fired Power Plants / Solar Farms etc.

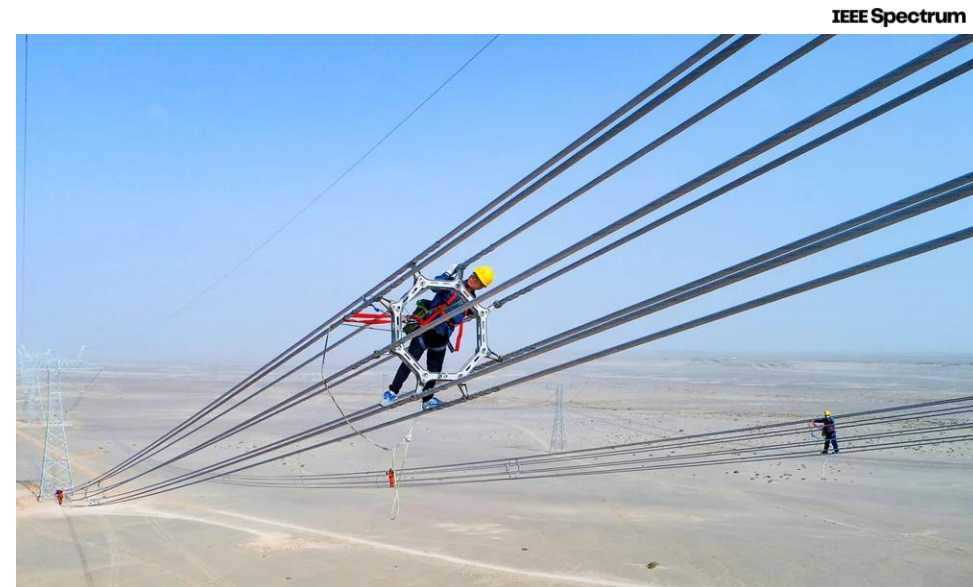

- 30'000 km UHVDC Links Built Over Last Decade in China / Emerging Nationwide Supergird Interconn. Reg. Grids

Remark The Global Grid

- “Super/Mega/Overlay Grid”-Concepts Proposed since 1950s — GENESIS (1994), DESERTEC (2003), etc.
- UHVDC Trans-Continental or Multi-National Supply & Trade of Clean Electricity

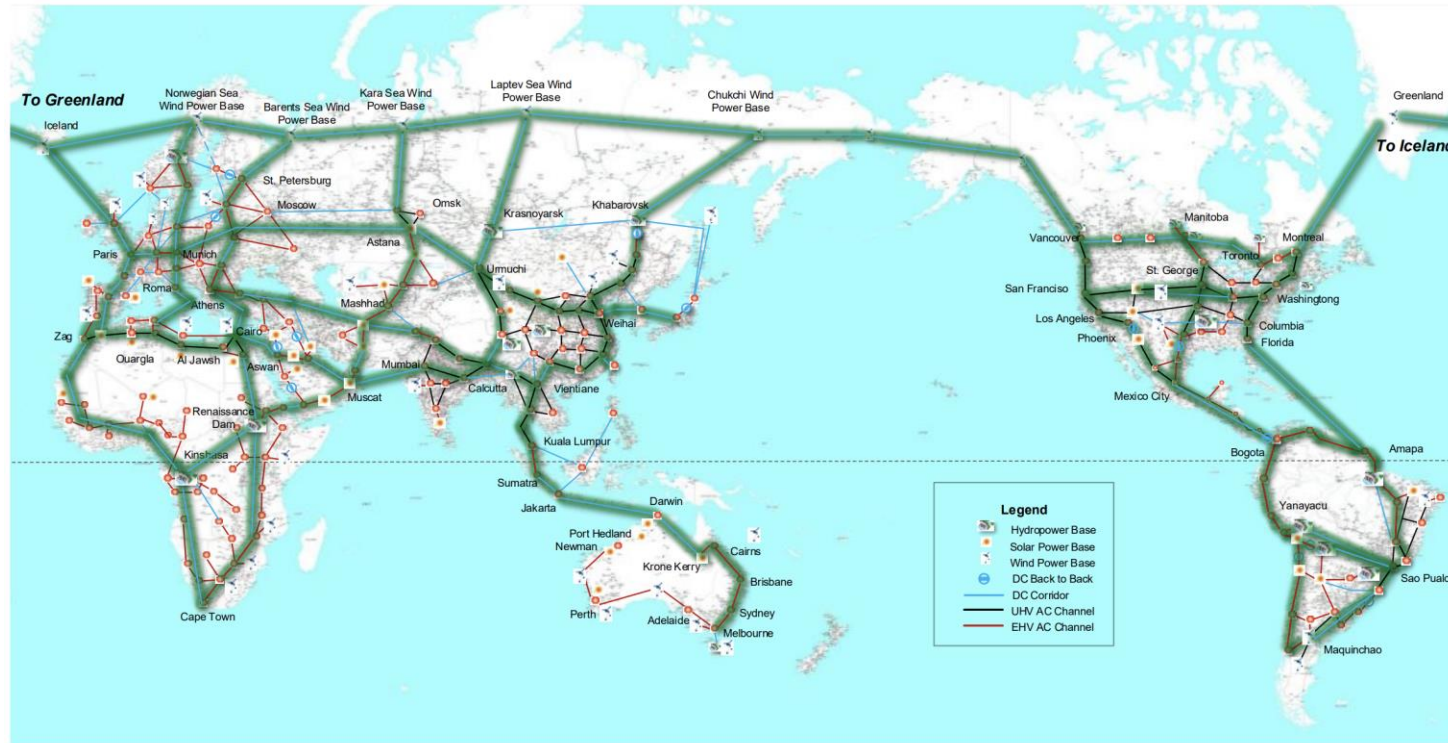

Source: GEIDCO 2018

- Example of the “Global Energy Interconnection Backbone Grid” (GEIDCO) Proposed by China in 2015

Falling-Off the „Net Energy Cliff“ (?)

- Analysis of Energy & Material Investments for **Global Transition from Fossil Fuels to RES in Electricity Sector**
- Transition to 100% RES by 2060 Could Decrease **EROEI from 12:1 to 3:1 by 2050 / Stabilizing @ 5:1**

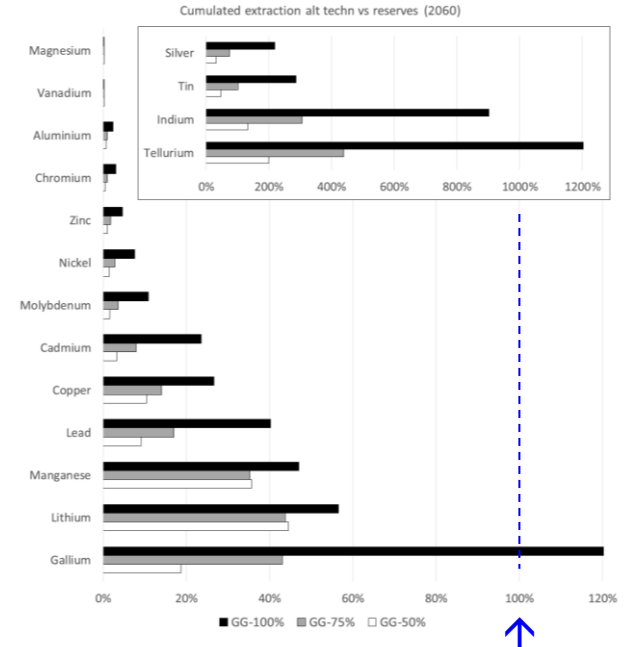
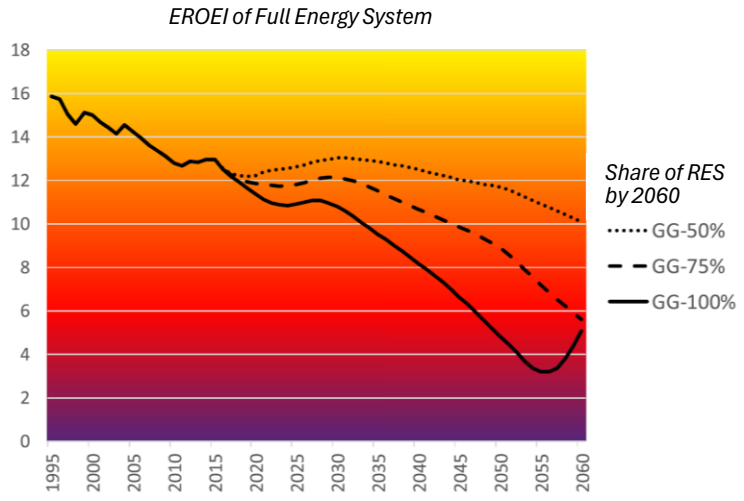
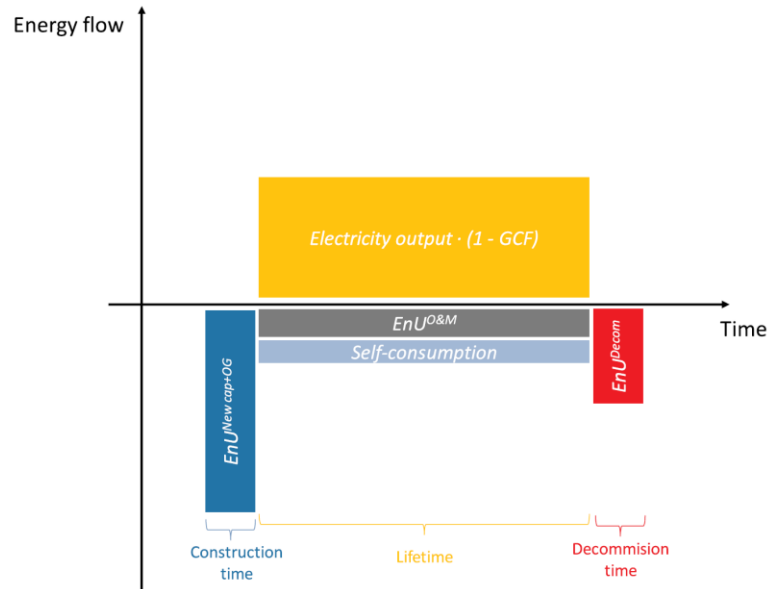

- Resulting EROEI Level Well Below Threshold Required to Sustain Complex Industrial Society
- Transition Could Drive Substantial Re-Materialization of the Economy / Deplete Critical Mineral Resources

“Peak Minerals/Metals”

————— *Raw Material Requirements / Dependencies* —————
Mining Constraints

„Peak Minerals/Metals“ of Net-Zero Scenario 1/3

- **Minerals/Metals Intensive Clean Energy Transition will Potentially Face Supply Shortages**
- **USD 2.1 Trillion Investment to Meet Net-Zero 2050 Demand / 6.5 Billion Tons of End-Use Materials**

Figure 1: Market balances for energy transition metals under BNEF's Economic Transition Scenario and Net Zero Scenario – expected supply surplus and supply deficits

Metal	Scenario	2024-2030	2031-2040	2041-2050
Steel	ETS	2024		
	NZS	2024		
Aluminum	ETS	2024		
	NZS	2024		
Copper	ETS	2024		
	NZS	2024		
Lithium	ETS	2025		
	NZS	2025		
Graphite	ETS	2028		
	NZS	2026		
Nickel	ETS		2030	
	NZS	2028		
Cobalt	ETS			2050
	NZS		2034	
Manganese	ETS			
	NZS			

Source: BloombergNEF. Note: Year is the first year in which a given metal is expected to enter a supply deficit. Only primary supply is considered in this table. All supply is mined nameplate capacity, apart from that for aluminum, graphite, and steel.

BloombergNEF

Primary copper demand scenarios versus mine supply potential

Wood Mackenzie

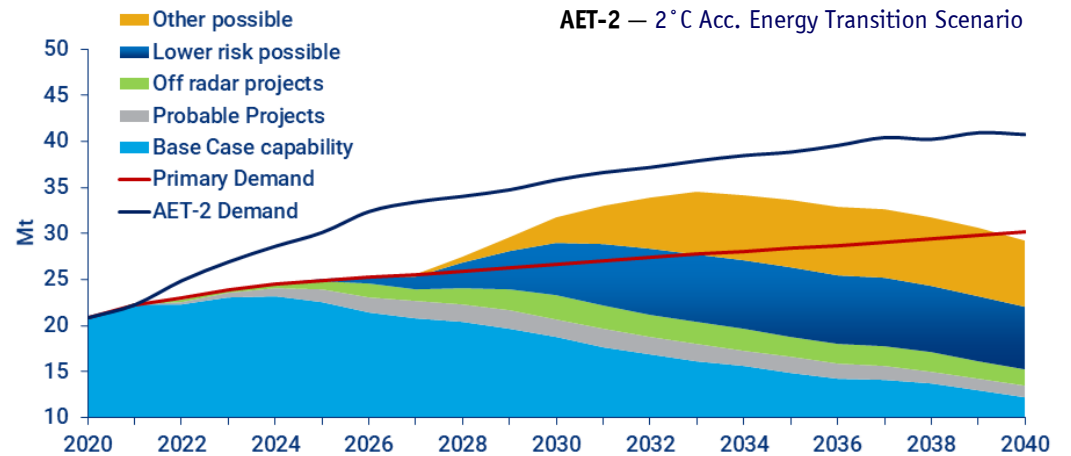

Source: Wood Mackenzie

- **50 New Lithium / 60 Nickel / 17 Cobalt Mines Required to Meet 2030 EV Battery Demand**
- **Development of a New Mine Takes 5...15 Years / x100 Million USD (!) – “Valley of Death”**

„Peak Minerals/Metals“ of Net-Zero Scenario 2/3

- Major Copper Discoveries are More Rare and Getting Progressively Deeper / > 1000 m Below Surface

Major copper discoveries are becoming less common and getting deeper...

(Selected major deposits, >3Mt contained copper)

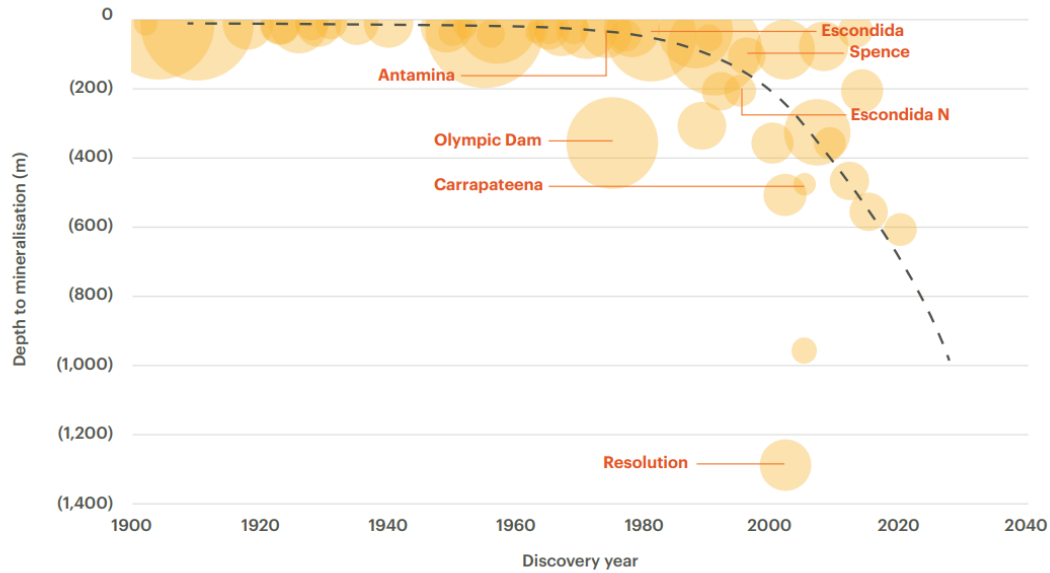

Source: MinEx Consulting; BHP analysis.



- Higher Mining Energy Intensity / Higher Production Costs

„Peak Minerals/Metals“ of Net-Zero Scenario 3/3

- Declining Ore Body Grades Require Ever-Increasing Tonnage to be Moved & Processed
- Higher Production Costs / Declining Amount of Economically Extractable Mineral

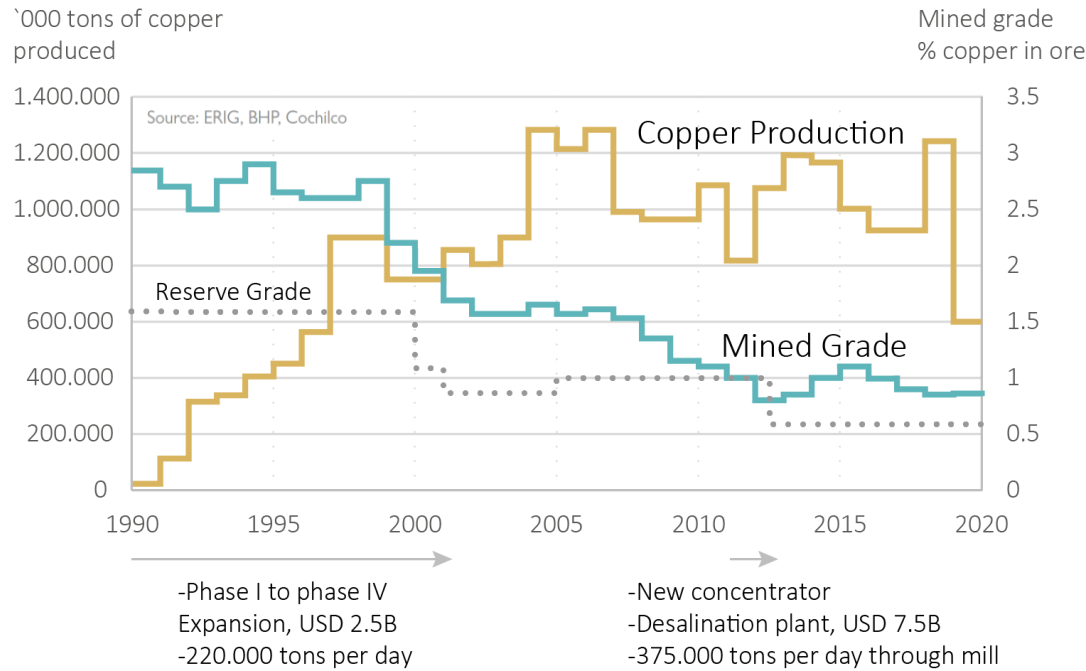

- Higher Diesel Consumption of Truck/Shovel Fleet | Higher Energy Effort for Grinding/Extraction per Unit Metal

Critical Mineral Dependencies

■ Production of Selected Minerals Critical for the Clean Energy Transition

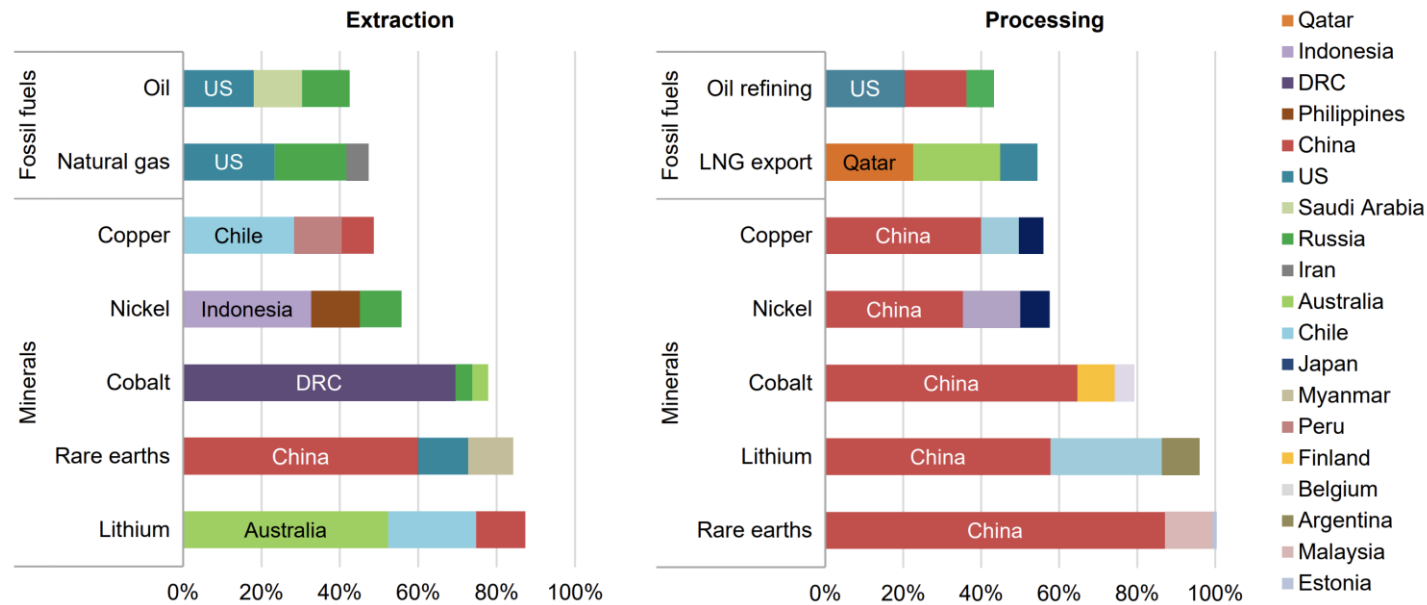

Source: IEA / The Role of Critical Minerals in Clean Energy Transitions (2021)

Shares of top three producing countries, 2019

■ Extraction & Processing More Geographically Concentrated than for Oil & Nat. Gas (!)

Remark EU Critical Raw Materials Act

- Europe's / Global Green Transition → Substantial Increase in Demand for Critical Raw Materials
- Geospatial Concentration of Supply Chains / Significant Geopolitical Risks

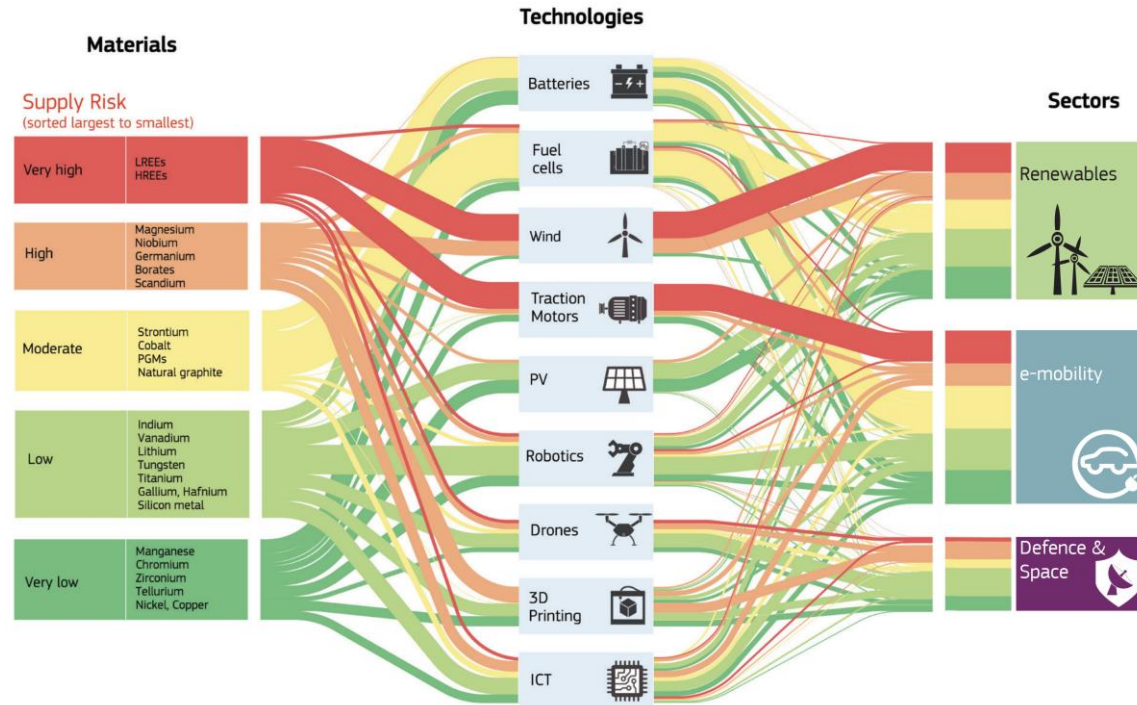

Source:  European Commission

- Access to Secure & Sustainable CRMs Supply Crucial for Achieving the 2030 Climate & Digital Objectives
- EU Critical Raw Material (CRM) Act 2024 → Sustainability & Circularity of CRMs on the EU Market



“Do-More-With-Less” & Max-EROEI Paradigm

Enabling Technologies / Concepts / Scaling Laws



Power Electronics 4.0 — “Reduce-to-the-Max”

- *Today’s Power Electronics Innovation Basically Contributes to Lower Environmental Impact*

- **Power Density** → *Red. of Resources*
- **Efficiency** → *Red. of Energy Use*
- **Robustness** → *Increased Lifetime*

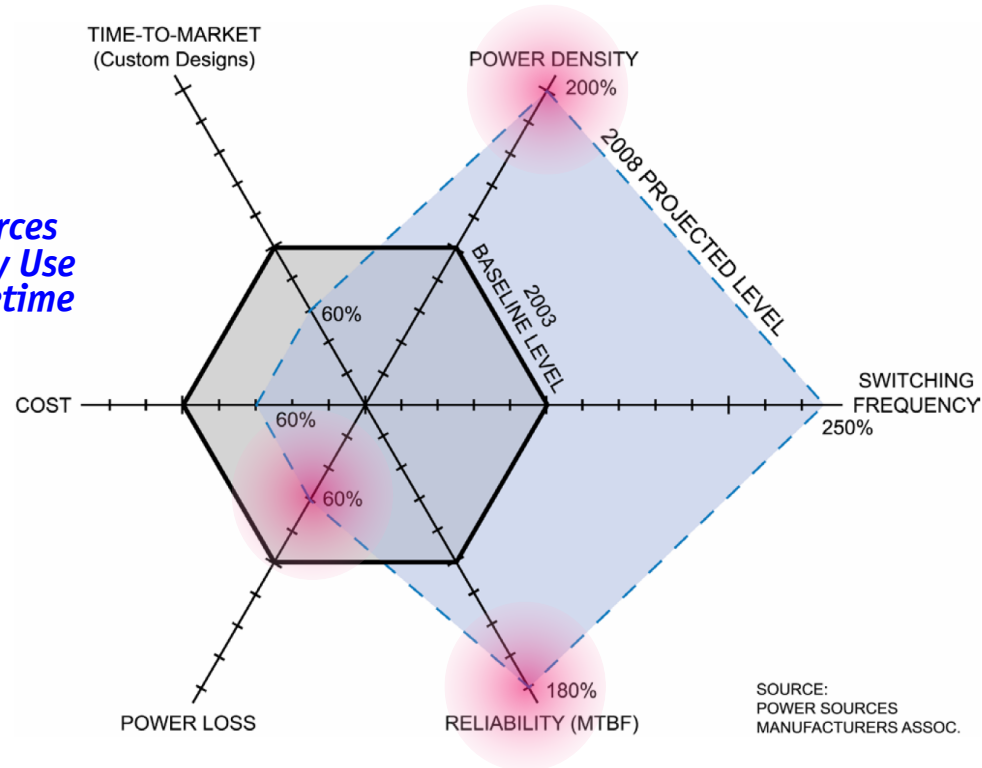

- *New Set of KPIs Mandatory to Meet Future Environmental Protection Objectives*

Low $R_{DS(on)}^*$ High-Voltage Devices

- *SiC MOSFETs / GaN HEMTs*
- *Low Conduction Losses*
- *High Efficiency*

$$R_{on}^* = \frac{4V_B^2}{\epsilon\mu_n E_C^3} \leftarrow$$

$$R_{on,SiC}^* \approx \frac{1}{300} R_{on,Si}^*$$

Source:  www.evincetechnology.com



Amount of semiconductor material needed to isolate 10,000V

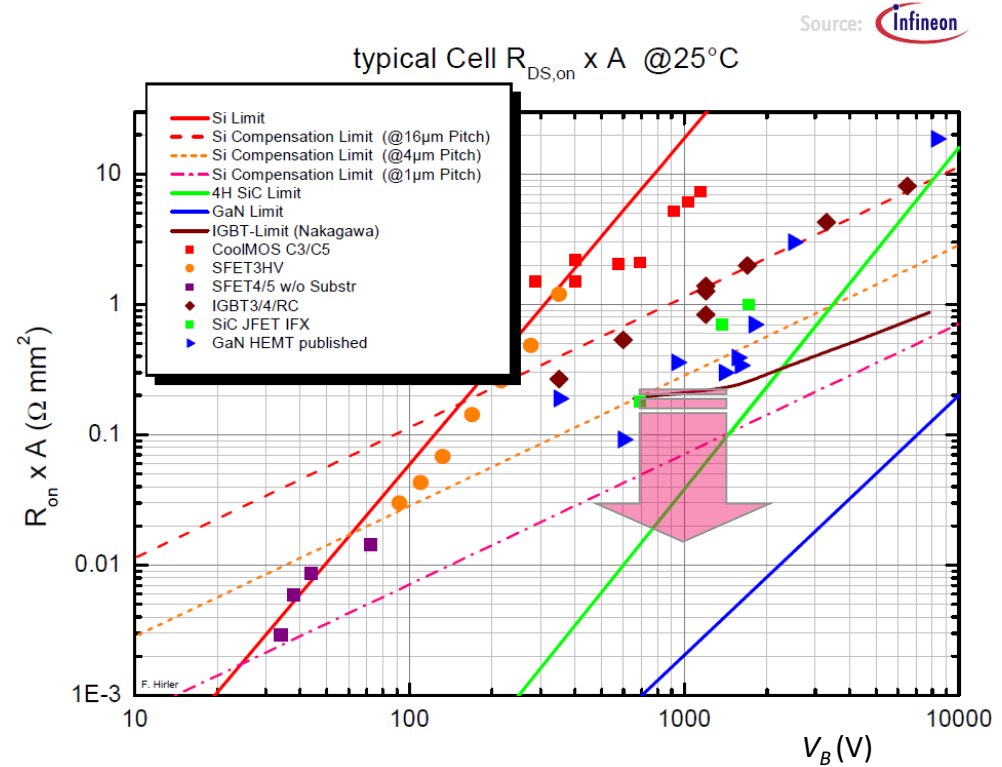

- *High Voltage Unipolar (!) Devices* → *Excellent Sw. Performance / High Power Density*

Digital Signal / Data Processing

- **Exponentially Improving uC / Storage Technology (!)**
- **Extreme Levels of Density (nm-Nodes) / Processing Speed**
- **Continuous Relative Cost Reduction**

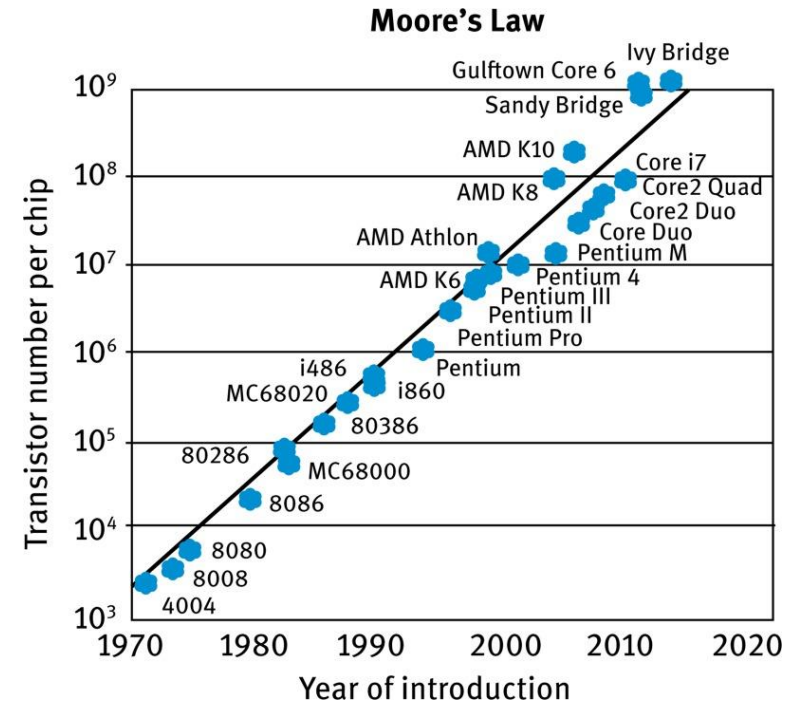
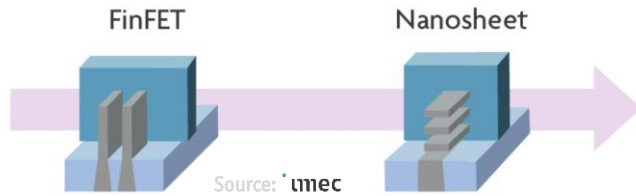

Source: Ostendorf & König / DeGruyter

- **Fully Digital Control / Distributed Intelligence — “Complexity Management”**
- **AI-Based Design / Digital Twins / Industrial IoT (IIoT)**

Scaling of Multi-Cell/Level Concepts

- **Reduced Ripple @ Same (!) Switching Losses**
- **Lower Overall On-Resistance @ Given Blocking Voltage**
- **Application of LV Technology to HV**



Source: R. Pilawa
Integrated Dual-Sided Half-Bridge Flying Capacitor Converter Switching Cell

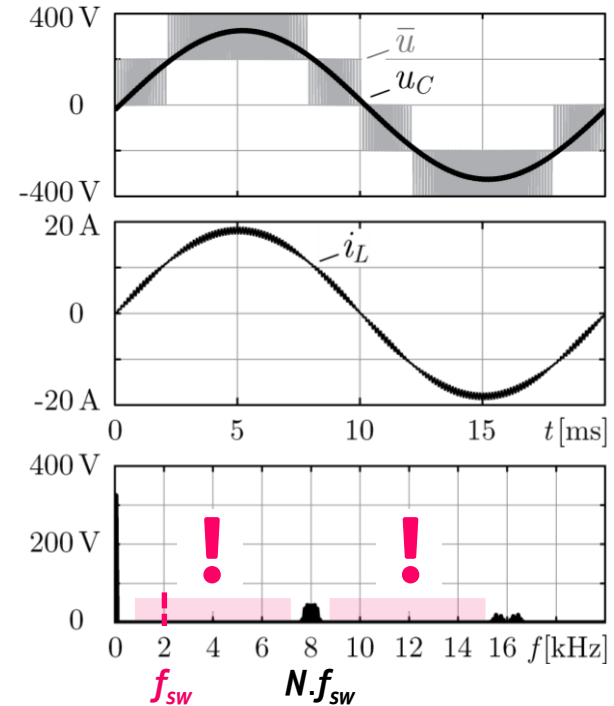
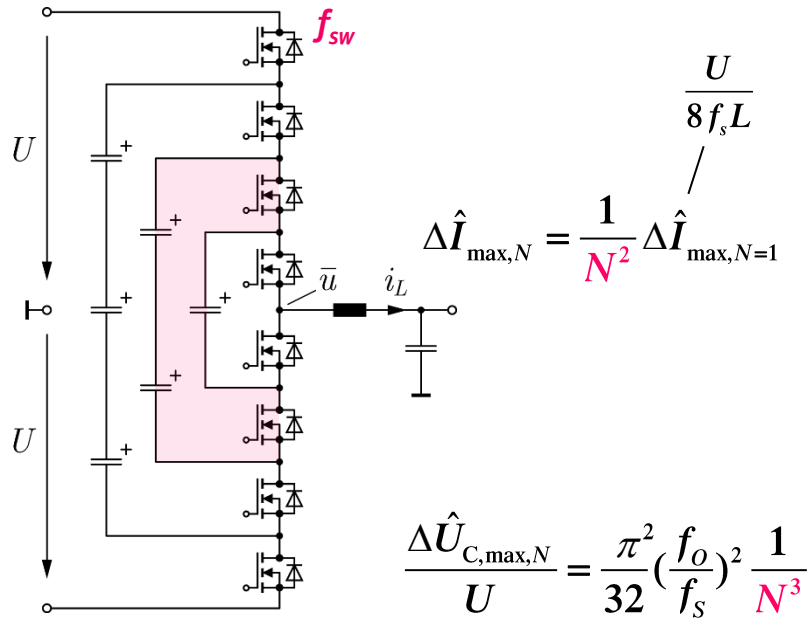

- **Scalability / Manufacturability / Standardization / Redundancy**

Scaling of DC Power System Losses

- Increase of R_L with Transmission Distance l
- Red. of R_L only Through Larger Conductor Cross Section A_{Cu}

→ Transmission Losses $P_{V,DC} = 2 \cdot \left(\frac{P}{2U_{DC}}\right)^2 \cdot R_L \sim \frac{1}{U_{DC}^2}$

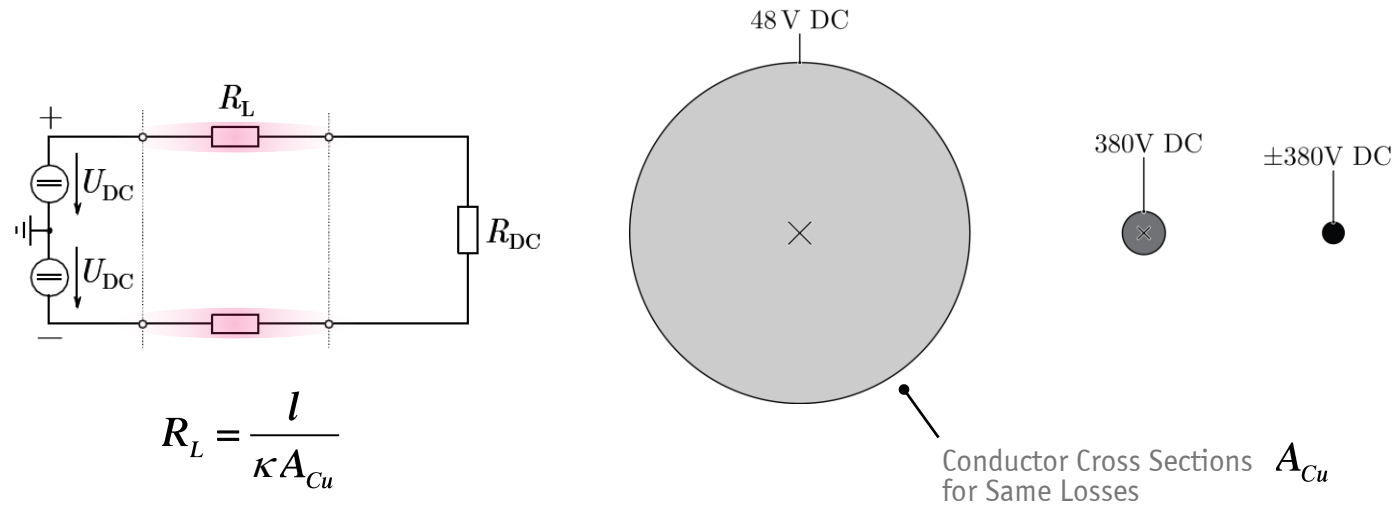

- Quadratic (!) Dependency of Losses on Voltage Level
- Allows Massive Reduction of Conductor Cross Section with Increasing Operating Voltage

3-Φ AC vs. DC Power Transmission

- **DC Voltage** → **Max. Utilization of Isolation Voltage** → **Lower Losses & Less Conductor Material (!)**

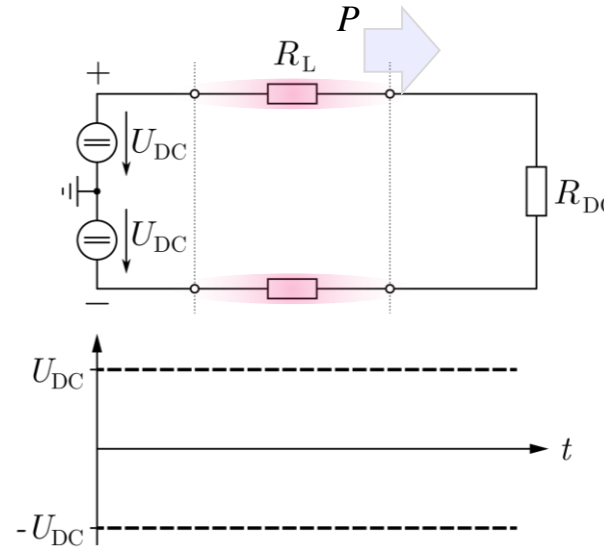
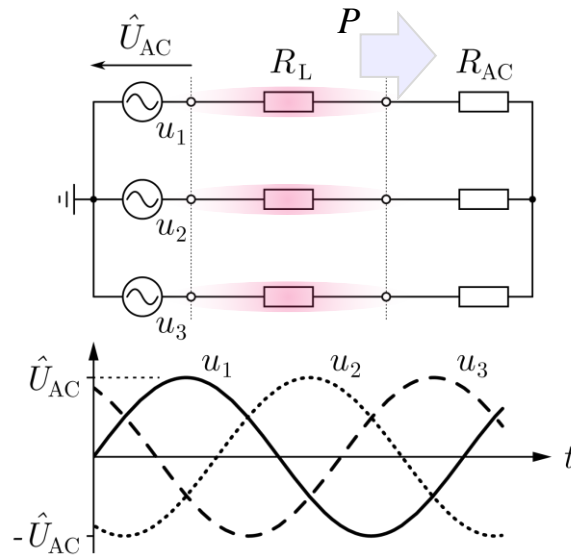

$$P_{V,AC} = 3 \cdot \left(\frac{\frac{1}{3}P}{U_{AC}}\right)^2 \cdot R_L$$

$$P_{V,DC} = 2 \cdot \left(\frac{P}{2U_{DC}}\right)^2 \cdot R_L$$

$$\frac{P_{V,DC}}{P_{V,AC}} = \frac{3}{2} \cdot \left(\frac{U_{AC}}{U_{DC}}\right)^2 \Big|_{U_{DC} = \hat{U}_{AC} = \sqrt{2} U_{AC}} = 0.75$$

- **Transformation of DC Voltage Level Requires Power Electr. Interfaces / "DC-Transformers" (!)**

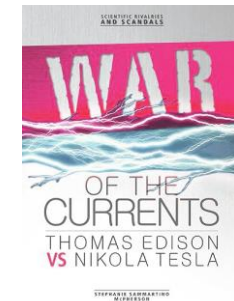

Scaling of Electric Machines

- **Active Volume Determined by Rated Motor Torque T**
- **Overall Size Decreases w/ Increasing Motor Speed @ Constant Rated Power P**

→ Power $P = T \cdot \omega = T \cdot 2\pi n$

→ Volume $L^3 \sim T \sim \frac{P}{2\pi n}$
↑

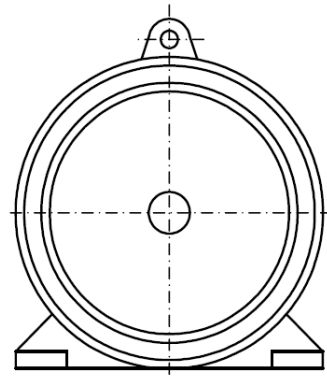

$$\begin{aligned} P &= P^* \\ n &= n^* \\ T &= T^* \end{aligned}$$

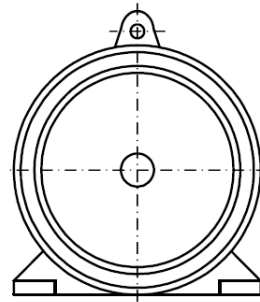

$$\begin{aligned} P &= P^* \\ n &= 2n^* \\ T &= \frac{1}{2}T^* \end{aligned}$$

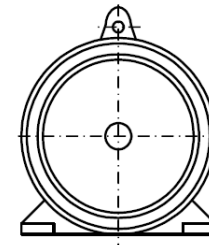

$$\begin{aligned} P &= P^* \\ n &= 4n^* \\ T &= \frac{1}{4}T^* \end{aligned}$$

- **Gearbox Required for Low Rated Speeds → Adds Volume and Losses**

Scaling of Transformers

- **Magnetic Core Cross Section** $A_{Core} = \frac{1}{\sqrt{2}\pi} \frac{U_1}{\hat{B}_{max} f} \frac{1}{N_1}$
- **Winding Window** $A_{Wdg} = \frac{2I_1}{k_W J_{rms}} N_1$

- **Construction Volume**

$$A_{Core} A_{Wdg} = \frac{\sqrt{2}}{\pi} \frac{P_t}{k_W J_{rms} \hat{B}_{max} f} \propto L^4$$

↑ ↑ ↑

P_t Rated Power
 k_W Window Utilization Factor
 \hat{B}_{max} .. Flux Density Amplitude
 J_{rms} ... Winding Current Density
 f Frequency

- **Low Frequency** → **Large Weight / Volume**
- **Trade-off** → **Volume vs. Efficiency**

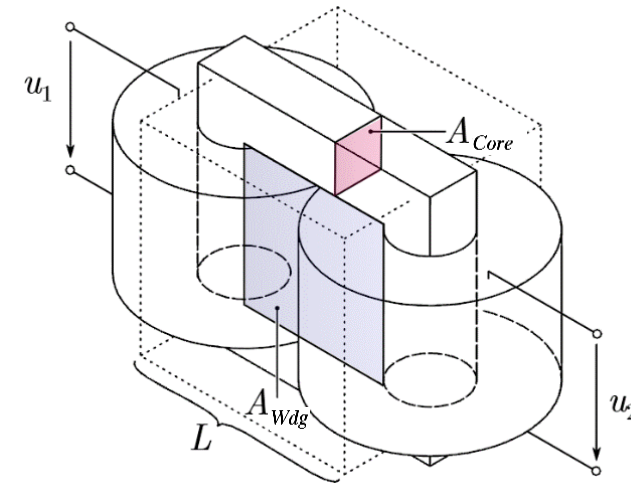



*Solid-State Transformer
EV Power Electronics*



Carbon Footprint of 3- Φ AC/DC SST 1/2

- 400kW Gen.1 & 1.2MW Gen.2 Fully-Modular Solid-State-Transformers (SST) w/ HF-Isolation Stages
- Lower Raw Material Effort / Lower Impact of Increasing Raw Material Costs

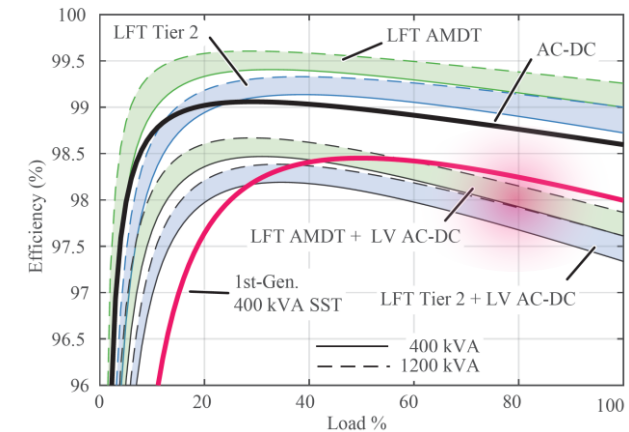
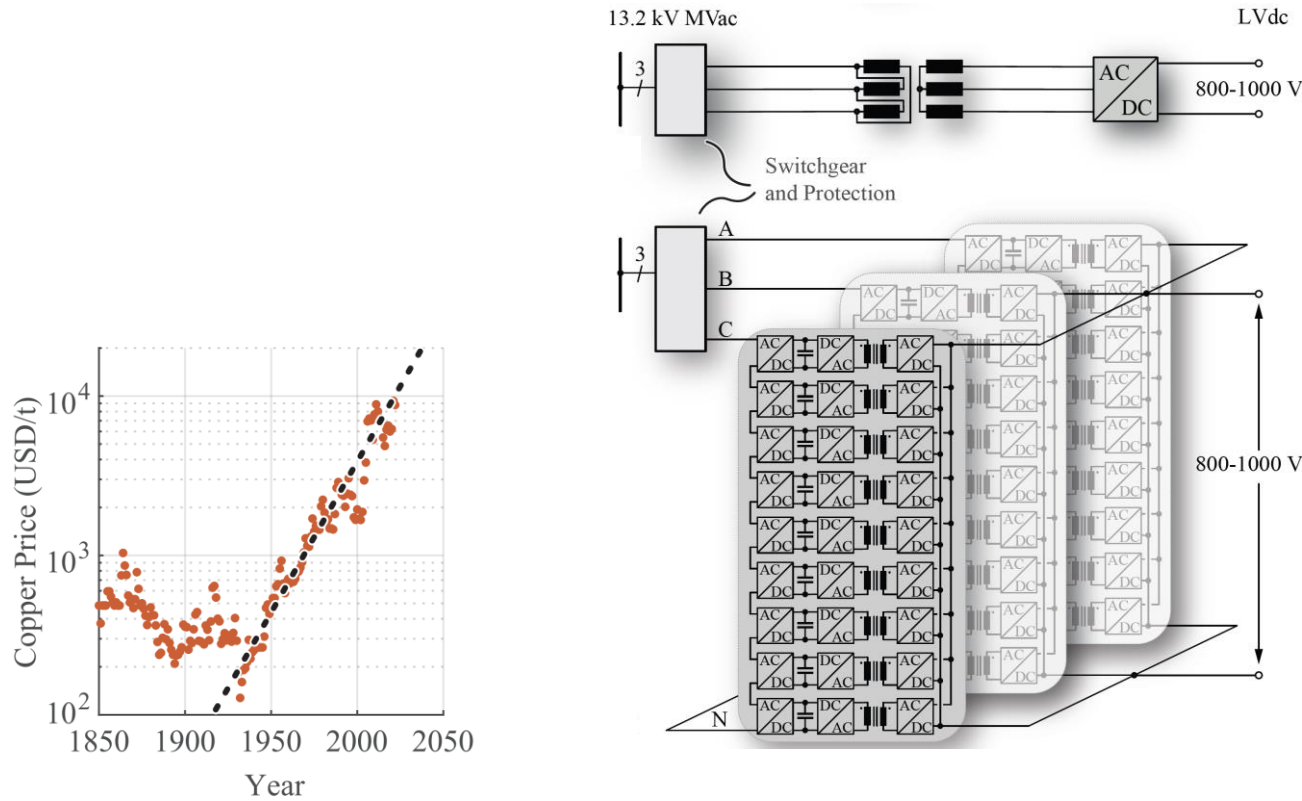

- Evaluation Against Dry-Type LFT-Based MVAC-LVDC Interface w/ Comparable Efficiency

Carbon Footprint of 3- Φ AC/DC SST 2/2

- 400kW Gen.1 & 1.2MW Gen.2 Fully-Modular Solid-State-Transformers (SST) w/ HF-Isolation Stages
- Lower Raw Material Effort / Lower Impact of Increasing Raw Material Costs

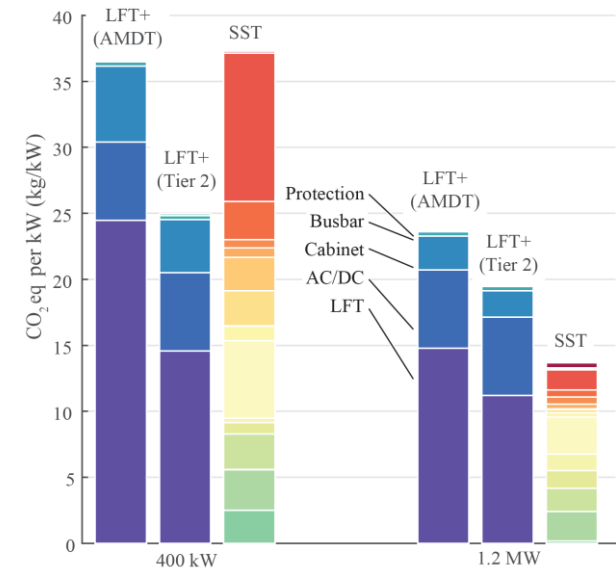
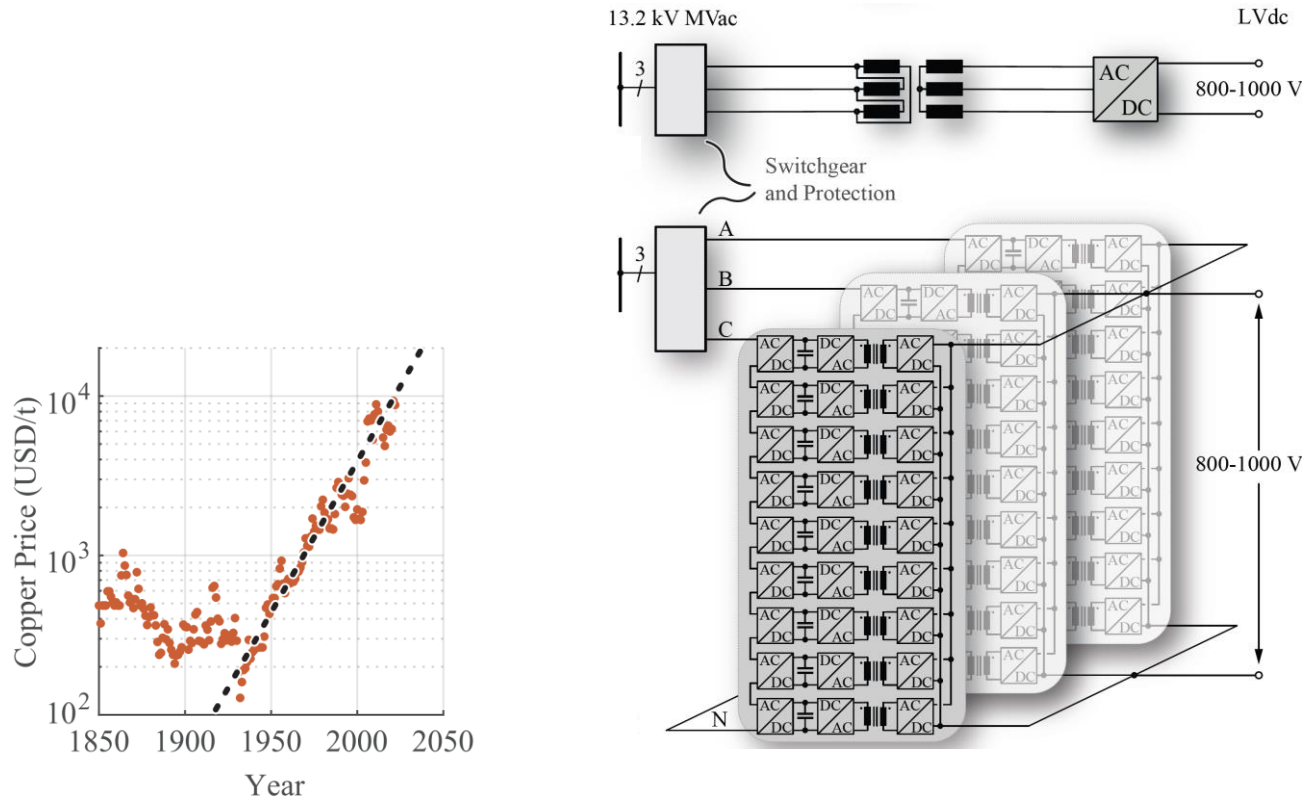

- Massive Improvement of SST Carbon Footprint [kg CO_{2,eq}/kW] from Gen.1 → Gen.2

Copper Used in xEVs

- *Cu Used for Traction Motors, Energy Storage, Power Electronics, HV & LV Distribution, Etc.*
- *ICE (2023) — 29.5kg | BEV Robotaxi in 2034 — 73kg (7.8kg Motor & Power Electronics)*

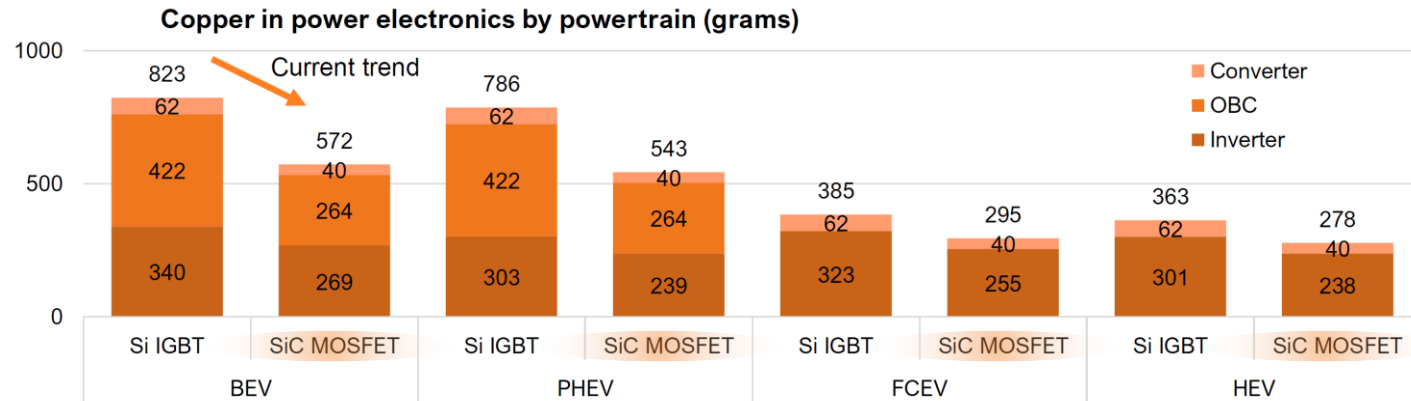

Source: IDTechEx

- *Transition Si IGBTs → SiC MOSFETs — 25...30% Decrease of Power Electronics Cu Intensity*

— Conclusion —



Future Zero-Waste Paradigm

- Growing Global E-Waste Streams / < 20% Recycled
- 120'000'000 Tons of Global E-Waste in 2050

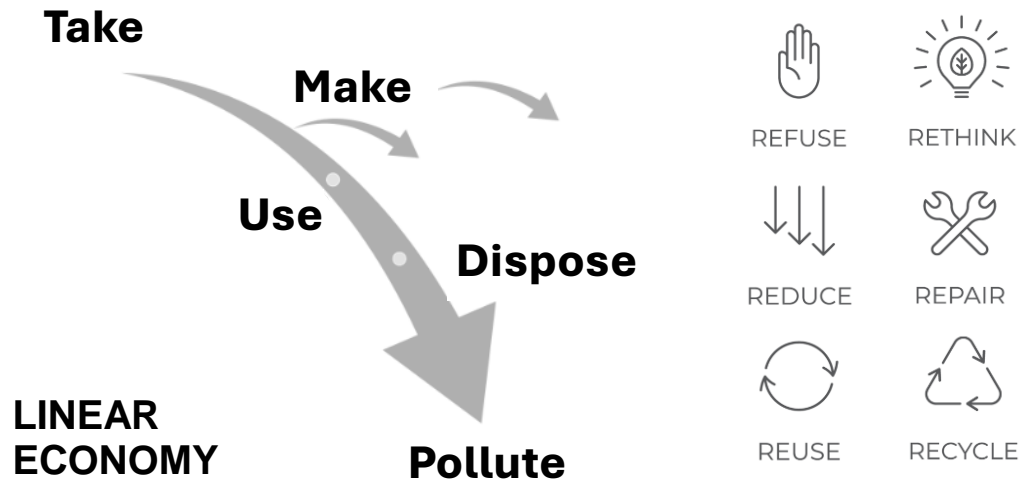

Source: CC 3.0 Catherine Weetman 2016

The Waste Hierarchy



Source: UTS — Institute for Sustainable Futures



- “Linear” Economy / Take-Make-Dispose → “6Rs” Towards Perpetual Flow of Resources / “Circular” Economy
- Recycling Aluminum 95% More Energy Efficient, Plastic 85%, Paper 50%, Glass 40% — “Downgrading” Problem

Power Electronics 5.0 — “Closing the Loop”

- “4R” Included Into the Design Process — Repair | Reuse | Refurbish | Recycle
- 80% of Environmental Impact of Products Locked-In at the Design Stage

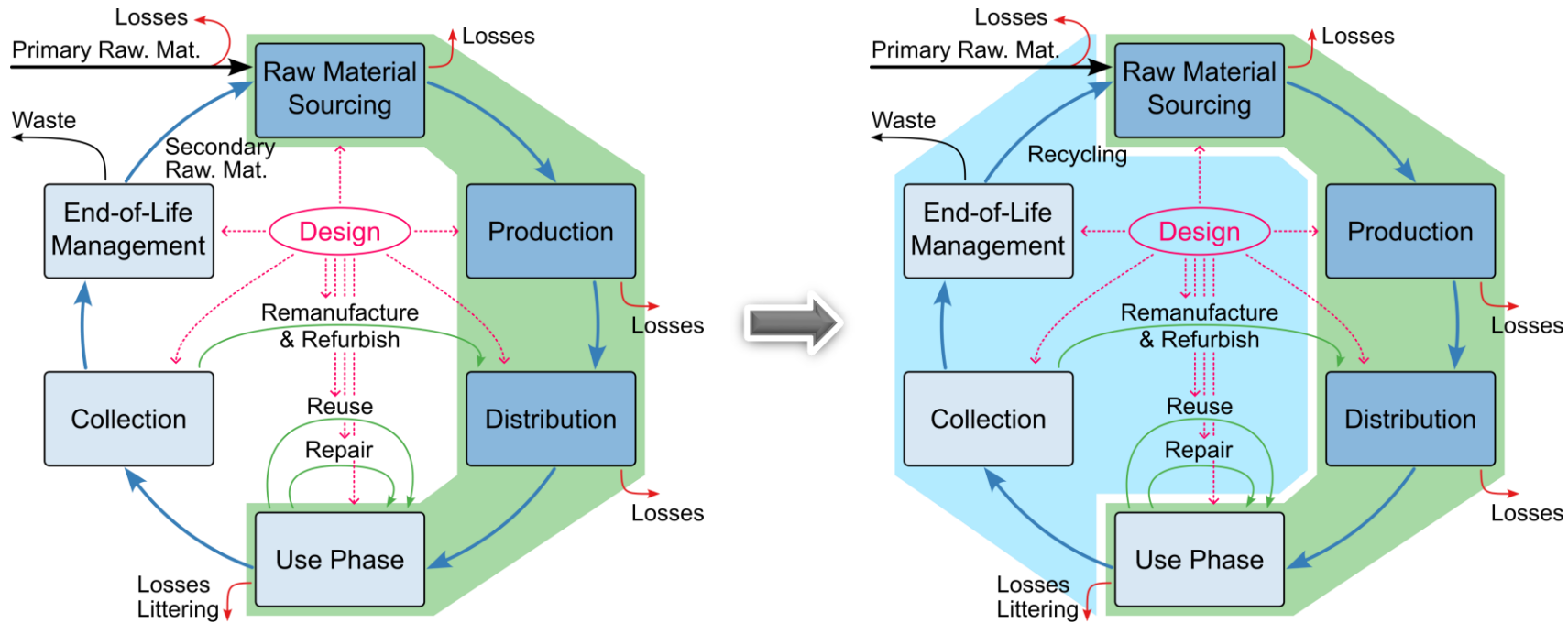

- “Life-Cycle Cost Perspective” — Potentially Advantageous for Suppliers & Customers
- Quantification of Repairability / Reusability / etc. Still to be Clarified

The Complexity Challenge

- **Technological Innovation — Increasing Level of Complexity & Diversity of Modern Materials / Products**
- **Exponentially Accelerating Technological Advancement (R. Kurzweil)**

Product Complexity / „Entropy“

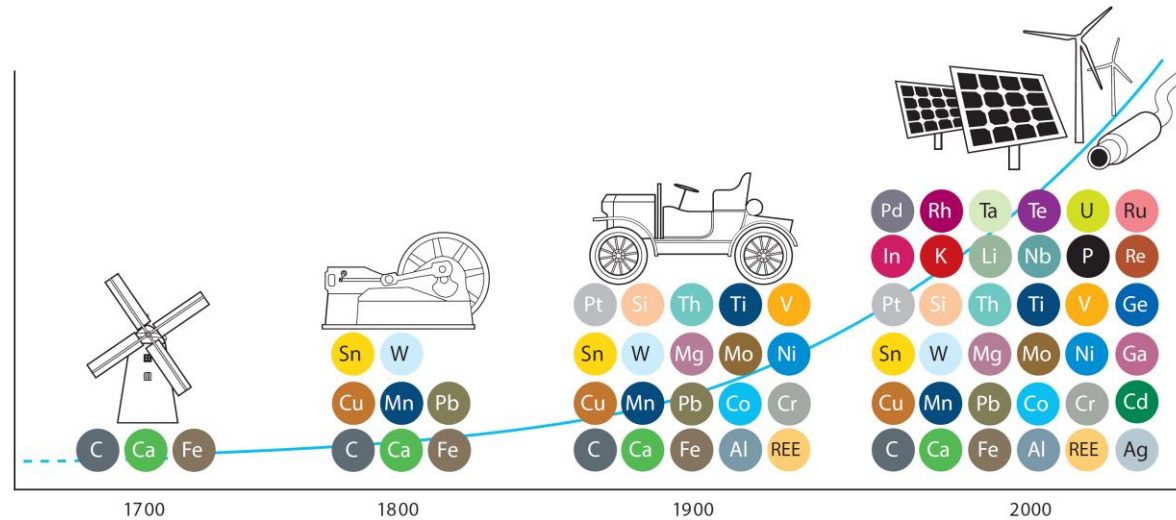

Source: Materials Critical to the Energy Industry An introduction

- **More than 60 Metallic Elements Involved in Pathways for Substitution of Conv. Energy Systems**
- **Ultra-Compact Systems / Functional Integration — Main Obstacles for EOL Material Separation (!)**

! Remark "Integration" — The Polar Opposite of CEC (?)

- **System in Package (SiP) Approach** — Isol. & Non-Isol. DC/DC Converters, PFC Rectifiers, etc.
- **Minim. of Parasitic Inductances / EMI Shielding / Integr. Thermal Management**

Source: 

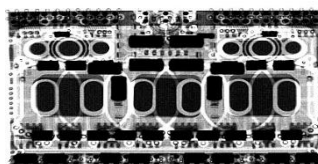
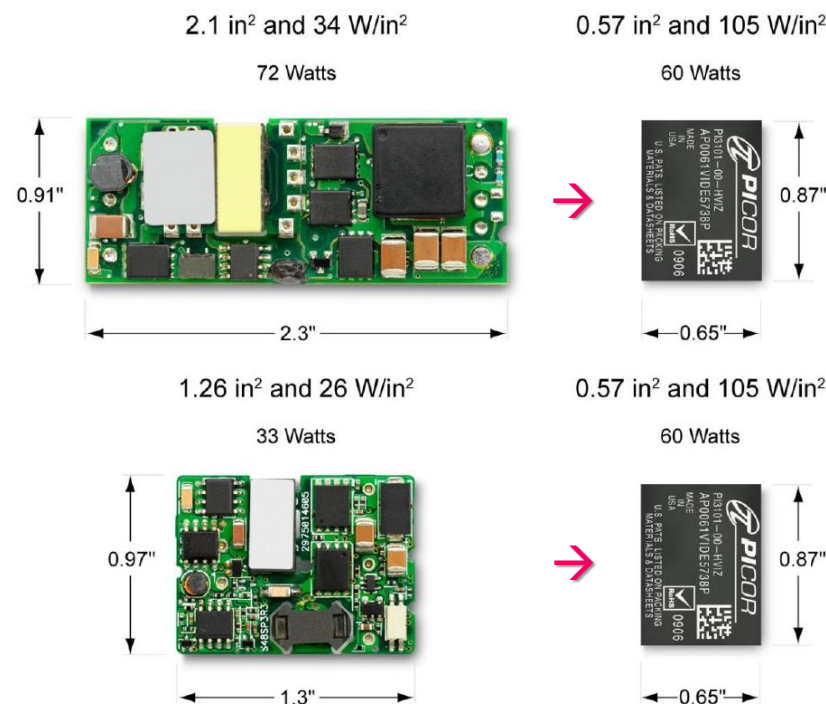

- **Extreme Power Density / Shrinks BOM**
- **Automated Manufacturing / High Reliability**
- **CEC - Circular Economy Compatibility (?)**

Power Electronics 5.0

- Power Electronics 1.0 → Power Electronics 5.0
- X-Technologies & X-Concepts
- New Main Performance Indicators (!)

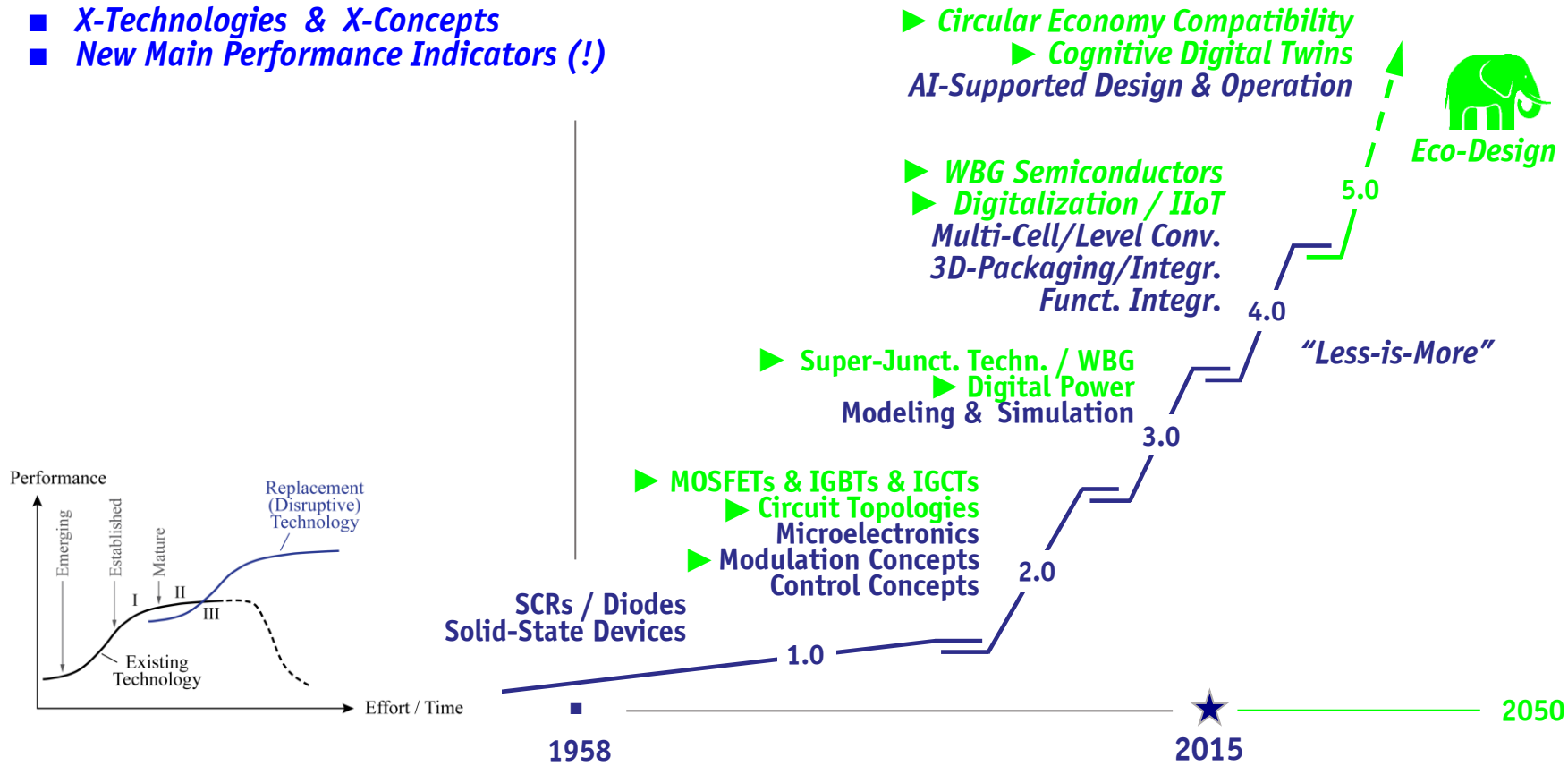



Thank you!

